

MODEL 192CDLR MEDIUM DUTY ROLL-TO-ROLL CHAIN DRIVEN LIVE ROLLER

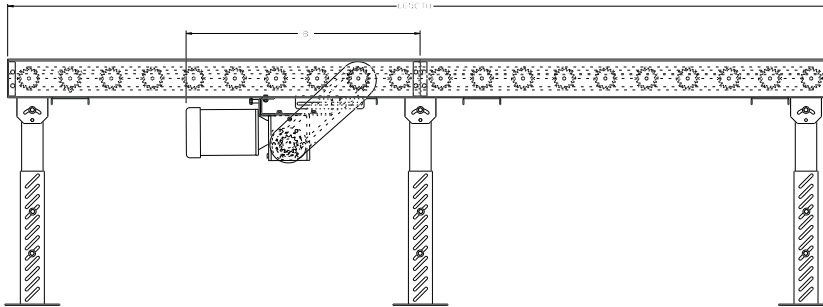

Conveyor shown with optional supports

Roach model 192CDLR is a medium duty chain driven live roller conveyor. This conveyor is designed to transport loads such as tote pans, castings, drums or pallet loads.

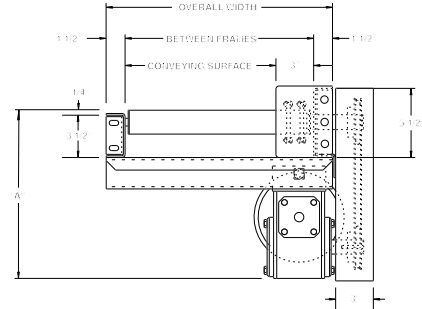

HP @ 45FPM	"A"	"B" MAX
1/3	13-1/8"	49-1/2"
1/2	13-1/8"	49-1/2"
3/4	13-1/2"	49-1/2"
1	13-3/4"	50-1/16"
1-1/2	14-5/8"	50-3/8"
2	15-1/2"	52-1/16"

SPECIFICATIONS

TREAD ROLLERS: 1.9" dia. x 12 ga. steel, model 192S with sprockets.

CHAIN DRIVE: Roll-to-roll no. 40 roller chain.

CENTER DRIVE: Reversible drive either side mounted or underside mounted (specify). Main drive roller is supported by precision, heavy duty, lubricated, ball bearing units.

CHAIN GUARD: The chain drive is completely enclosed along the entire length of the conveyor.

ROLLER CENTERS: 4", 6", 8" or 12" centers available.

SPEED: 45 FPM, constant.

BEARINGS: Removable type, zinc-plated, grease packed, labyrinth sealed.

BED: 5-1/2" x 1-1/2" x 10 ga. and 3-1/2" x 1-1/2" x 10 ga. formed steel channel frame.

MOTOR DRIVE: 1/3 HP, 230/460/3, 60 cycle, ODP right angle gear motor.

ELECTRICAL CONTROLS: Optional.



SPECIFICATION TABLE

■ 24 hour shipment

UNIT WEIGHTS (FOR 4" AND 8" ROLLER CENTERS ONLY)																			
CONVEYOR LENGTH		5'		10'		20'		30'		40'		50'		60'		70'		80'	
CONV. SURFACE	BF	4" RC	8" RC	4" RC	8" RC	4" RC	8" RC	4" RC	8" RC	4" RC	8" RC	4" RC	8" RC	4" RC	8" RC	4" RC	8" RC	4" RC	8" RC
12"	15"	334	291	509	431	859	703	1209	948	1659	1247	1909	1519	1790	2065	2340			
18"	21"	372	319	572	474	969	773	1367	1073	1764	1372	2161	1671	1971	2276	2581			
24"	27"	409	351	634	516	1079	843	1524	1170	1969	1497	2414	1824	2251	2476	2801			
30"	33"	452	379	697	559	1190	914	1683	1269	2175	1623	2668	1978	2333	2688	3043			
36"	39"	469	406	739	600	1278	950	1817	1340	2356	1720	2895	2100	2480	2865	3250			
42"	45"	524	430	819	640	1407	1049	1994	1457	2581	1865	3169	2274	2684	3099	3514			
48"	51"	562	463	882	683	1517	1119	2152	1555	2788	1992	3423	2428	2864	3299	3734			

UNIT WEIGHTS (FOR 6" AND 12" ROLLER CENTERS ONLY)																			
CONVEYOR LENGTH		5'		10'		20'		30'		40'		50'		60'		70'		80'	
CONV. SURFACE	BF	6" RC	12" RC	6" RC	12" RC	6" RC	12" RC	6" RC	12" RC	6" RC	12" RC	6" RC	12" RC	6" RC	12" RC	6" RC	12" RC	6" RC	12" RC
12"	15"	307	285	457	405	755	651	1053	897	1351	1143	1647	1389	1946	1634	2246	1884	2546	2134
18"	21"	341	301	506	441	837	707	1169	974	1500	1240	1831	1506	2163	1773	2493	2043	2823	2313
24"	27"	370	331	555	476	921	763	1287	1050	1653	1337	2019	1624	2385	1911	2755	2201	3125	2491
30"	33"	405	358	605	513	1006	822	1407	1131	1807	1439	2208	1748	2609	2057	3009	2367	3409	2677
36"	39"	418	363	633	528	1066	856	1499	1184	1932	1512	2365	1840	2798	2168	3228	2498	3658	2828
42"	45"	465	406	700	581	1169	931	1637	1280	2105	1629	2574	1979	3044	2330	3514	2680	3984	3030
48"	51"	499	432	749	617	1251	987	1753	1357	2256	1728	2753	2090	3260	2468	3760	2838	4260	3208

OPTIONAL EQUIPMENT

SPEED: Constant speed 1.5-100 FPM; DC variable speed; AC inverter variable speed. Other constant or variable speeds available. **NOTE: CAPACITY CHANGES WITH SPEED. 100 FPM MAX. WITH ROLL-TO-ROLL CHAIN DRIVE.**

MOTORS: Available through 3 HP in TEFC, explosion proof, dirty duty, brake motor, 115/230/1, 575/3, etc.

FLOOR SUPPORTS: Supports, knee braces, casters and polytief supports available. See Conveyor Accessories.

UNDERTRUSSED BED: Available to provide clearance underneath unit at bed joint locations. Specify location for undertrussing and desired clearance underneath unit. Consult factory.

GUARD RAILS: 1-3/4" x 1" formed channel (model GC), adjusts horizontally to 8" wider than roller and vertically to 6" above roller; formed steel fixed (model FSG in 2", 4" and 6" heights; fixed channel (model FC); 1-1/2" angle (model GA1-1/2). See Conveyor Accessories.

CEILING HANGERS: 5/8" dia. threaded rod with hardware to attach rods to conveyor. Provides 6' clearance between ceiling and TOR (furnished in place of floor supports). See Conveyor Accessories.

ELECTRICAL CONTROLS: Magnetic starter; one direction manual starter; momentary start/stop push button station; limit switch, photo relay; others available.

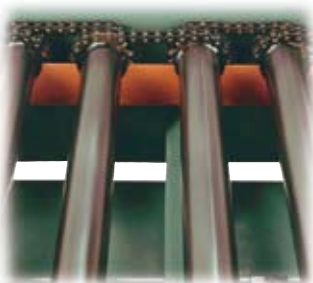

ROLLER TO ROLLER CHAIN DRIVE
(guard removed for clarity)



OPTIONAL TOP ROLLER GUARD MOUNTED DRIVE



MODEL 192CDLRC MEDIUM DUTY CHAIN DRIVEN LIVE ROLLER CURVE



Conveyor shown with optional supports

Roach 192CDLRC is a medium duty chain driven live roller curve, designed to transport medium duty loads such as castings or drums. NOTE: When conveying medium duty pallet loads, use model 254TCDLRC, opposite page, to maintain product orientation.

SPECIFY MODEL NUMBER PER EXAMPLE
192CDLRC-27-45-L
192CDLRC-(between frames)-(degree)-(left or right)

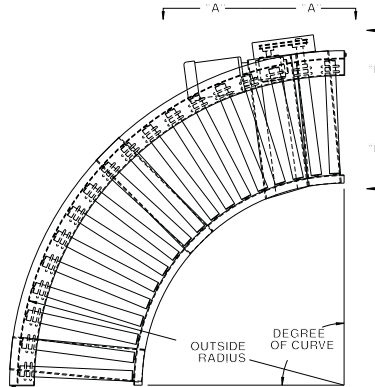
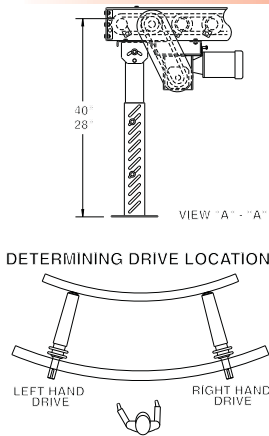
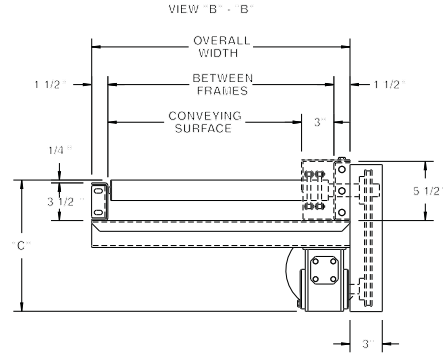

UNIT		90°		45°		
BF	CONV. SURFACE	OUTSIDE RADIUS	QTY. RLRS.	WT (lbs.)	QTY. RLRS.	WT. (lbs.)
15"	12"	4'-10-3/4"	18	339	9	265
21"	18"	4'-10-3/4"	18	374	9	277
27"	24"	4'-10-3/4"	18	409	9	292
33"	30"	8'-15/16"	30	543	15	313
39"	36"	8'-15/16"	30	586	15	337
45"	42"	8'-15/16"	30	633	15	364
51"	48"	8'-15/16"	30	681	15	391

CHAIN DRIVEN LIVE ROLLERS

SPECIFICATIONS

TREAD ROLLERS: 1.9" dia. x 12 ga. steel, model 192S with sprockets.*

CHAIN DRIVE: Roller to roller with No. 40 circular roller chain.

END DRIVE: Reversible drive either side mounted or underside (specify). Main drive roller is supported by precision, heavy duty, lubricated, ball bearing units.

CHAIN GUARD: Chain drive is enclosed, top and bottom, along entire length of conveyor.

BED: 5-1/2" x 1-1/2" x 10 ga. and 3-1/2" x 1-1/2" x 10 ga. formed steel channel frame.

BEARINGS: Removable type, heavy duty bearings, zinc plated, grease packed, labyrinth sealed.

MOTOR DRIVE: 1/3 HP, 230/460/3, 60 cycle, ODP right angle gear motor.

SPEED: 45 FPM, constant.

DRIVE LOCATION: Drive located on outside of curve. Specify right hand drive or left hand drive (drive hand determined with reference point located at outside of curve).

ROLLER CENTERS: 5" RC measured at outside radius of curve.

ELECTRICAL CONTROLS: Optional.

HP @ 45FPM	"C"
1/3, 1/2	13-1/8"
3/4	13-1/2"
1	13-3/4"
1-1/2	14-5/8"
2	15-1/2"

OPTIONAL EQUIPMENT

SPEED: Constant speed 1.5-60 FPM; DC variable speed; AC inverter variable speed. Other constant or variable speeds available.

NOTE: CAPACITY CHANGES WITH SPEED. 100 FPM MAX. WITH ROLLER-TO-ROLLER CHAIN DRIVE.

MOTORS: Available through 3 HP in TEFC, explosion proof, dirty duty, 115/230/1, 575/3, etc.

FLOOR SUPPORTS: Supports, knee braces, casters, ceiling hangers and polytier supports available. See Conveyor Accessories.

ELECTRICAL CONTROLS: Magnetic or manual starter; limit switch; others available.

*NOTE: Orientation of product may be affected because of straight rollers in curve. To maintain orientation, use tapered roller curve.

■ 4 week shipment



MODEL 254TCDLRC MEDIUM DUTY TAPERED ROLLER CHAIN DRIVEN LIVE ROLLER CURVE

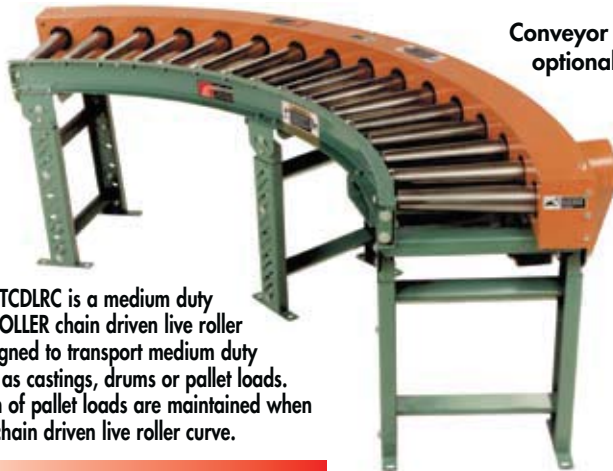

Conveyor shown with optional supports

Model 254TCDLRC is a medium duty TAPERED ROLLER chain driven live roller curve, designed to transport medium duty loads such as castings, drums or pallet loads. Orientation of pallet loads are maintained when using this chain driven live roller curve.

SPECIFY MODEL NUMBER PER EXAMPLE
254TCDLRC-39-90-R
254TCDLRC-(between frames)-(degree)-(left or right)

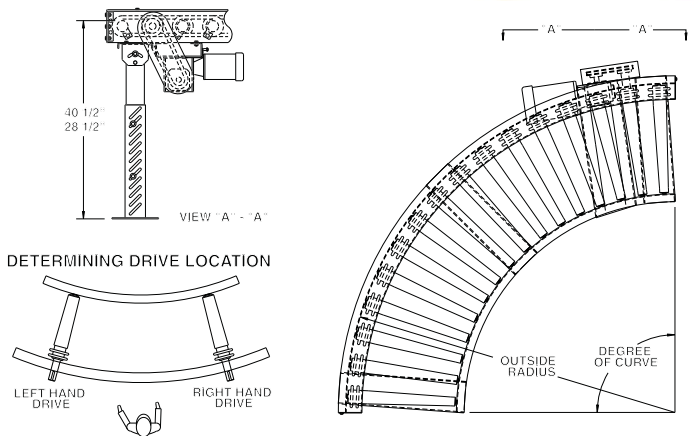
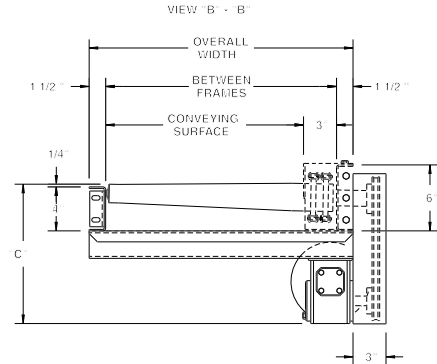

UNIT		90°		45°		
BF	CONV. SURFACE	OUTSIDE RADIUS	QTY. RLRS.	WT (lbs.)	QTY. RLRS.	WT. (lbs.)
15"	12"	5'-2-1/2"	16	344	8	208
21"	18"	5'-2-1/2"	16	372	8	225
27"	24"	5'-2-1/2"	16	403	8	243
33"	30"	7'-9-1/4"	24	447	12	263
39"	36"	7'-9-1/4"	24	486	12	310
45"	42"	7'-9-1/4"	24	528	12	334
51"	48"	7'-9-1/4"	24	559	12	359

SPECIFICATIONS

TREAD ROLLERS: 2-1/2" dia. to 1-11/16" dia. x 14 ga. steel tapered rollers, model 254T with sprockets.

CHAIN DRIVE: Roller to roller with No. 60 circular roller chain.

END DRIVE: Reversible drive, side mounted or underside (specify). Main drive roller is supported by precision, heavy duty, lubricated, ball bearing units.

ROLLER CENTERS: 6" RC measured at outside radius of curve.

CHAIN GUARD: Chain drive is enclosed, top and bottom, along entire length of conveyor.

BEARINGS: Removable type, heavy duty bearings, zinc plated, grease packed, labyrinth sealed.

MOTOR DRIVE: 3/4 HP, 230/460/3, 60 cycle, ODP right angle gear motor.

BED: 6" x 1-1/2" x 10 ga. and 4" x 1-1/2" x 10 ga. formed steel channel frame.

SPEED: 45 FPM, constant.

DRIVE LOCATION: Drive located on outside of curve. Specify right hand drive or left hand drive (drive hand determined with reference point located at outside of curve).

ELECTRICAL CONTROLS: Optional.

HP @ 45FPM	"C"
1/3, 1/2	13-5/8"
3/4	14"
1	14-1/4"
1-1/2	15-1/8"
2	16"

OPTIONAL EQUIPMENT

SPEED: Constant speed 1.5-60 FPM; DC variable speed; AC inverter variable speed. Other constant or variable speeds available.
NOTE: CAPACITY CHANGES WITH SPEED. 100 FPM MAX. WITH ROLLER-TO-ROLLER CHAIN DRIVE.

MOTORS: Available through 3 HP in TEFC, explosion proof, dirty duty, 115/230/1, 575/3, etc.

FLOOR SUPPORTS: Supports, knee braces, casters, ceiling hangers and polytier supports available. See Conveyor Accessories.

ELECTRICAL CONTROLS: Magnetic or manual starter; limit switch; others available.



■ 4 week shipment

MODEL 251CDLR HEAVY DUTY CHAIN DRIVEN LIVE ROLLER

24 HOUR SHIPMENTS INCLUDE LENGTHS 5'-0" TO 80'-0" AS DETAILED BELOW



Conveyor shown with optional supports

Model 251CDLR is a heavy duty chain driven live roller conveyor, specifically designed to transport heavy loads such as tote pans, castings, drums, pallet loads, etc. It is especially suited for carrying loads in the presence of oil and other such contaminants.

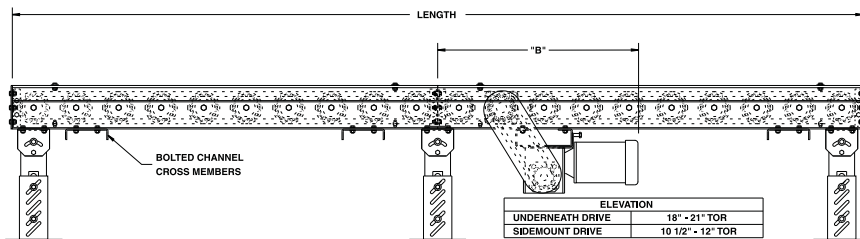
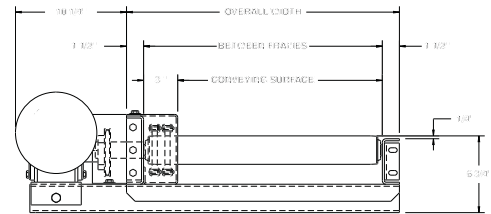
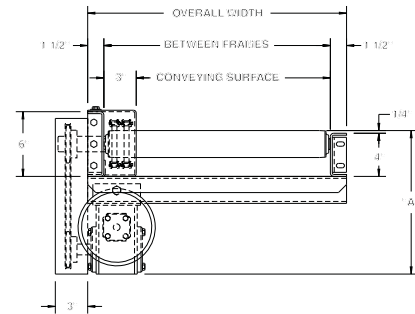

HP @ 35FPM	"A" MAX	"B" MAX
3/4	13"	38-13/16"
1	13-1/4"	39-1/8"
1-1/2	14-1/8"	39-1/8"
2	15"	40-13/16"

SPECIFICATIONS

TREAD ROLLERS: 2-1/2" dia. x 11 ga. steel rollers, model 251S with sprockets.

CHAIN DRIVE: Roller to roller with No. 60 roller chain.

ROLLER CENTERS: 3", 4-1/2", 6", 9" or 12". (SEE NOTE FOR 3" RC)

CENTER DRIVE: Reversible drive either side mounted or underside mounted (specify). Main drive roller is supported by precision, heavy duty, lubricated, ball bearing units.

BED: 6" x 1-1/2" x 7 ga. and 4" x 1-1/2" x 7 ga. formed steel channel frame. Bed sections attached with couplings and floor supports.

MOTOR DRIVE: 3/4 HP, 230/460/3, 60 cycle, ODP right angle gear motor.

BEARINGS: Precision ABEC bearings.

CHAIN GUARD: The chain drive is completely enclosed along the entire length of the conveyor.

BED LENGTHS (4-1/2" or 9" RC): Intermediate bed section lengths 3'-0", 3'-9", 4'-6", 5'-3", 6'-0", 6'-9", 7'-6", 8'-3", 9'-0" and 9'-9" increments. Minimum overall conveyor length with drive 5'-3". Maximum overall conveyor length: 58'-6" with 4-1/2" RC; 78'-0" with 9" RC.

BED LENGTHS (6" or 12" RC): Intermediate bed section lengths are available in 1'-0" increments. Minimum overall conveyor length with drive 5'-0". Maximum overall conveyor length 80'-0".

ELECTRICAL CONTROLS: Optional.

SPEED: 35 FPM, constant.

***NOTE 3" RC:** 3" RC are available with #40 chain on 40-14 double single sprocket sleeves.



OPTIONAL 3" RC NOW AVAILABLE
(guard removed for clarity)



SPECIFICATION TABLE

■ 24 hour shipment

UNIT WEIGHTS (FOR 4-1/2" AND 9" ROLLER CENTERS ONLY)																		
CONVEYOR LENGTH		5'-3"		9'-9"		19'-6"		29'-3"		39'		48'-9"		58'-6"		68'-3"		78'
CONV. SURFACE	BF	4-1/2" RC	9" RC	4-1/2" RC	9" RC	4-1/2" RC	9" RC	4-1/2" RC	9" RC	4-1/2" RC	9" RC	4-1/2" RC	9" RC	4-1/2" RC	9" RC	9" RC	9" RC	9" RC
12"	15"	317	282	522	452	928	788	1304	1099	1699	1427	2105	1763	2511	2099	2503	2844	
18"	21"	347	307	577	497	1033	873	1455	1221	1899	1588	2355	1964	2811	2340	2753	3129	
24"	27"	377	330	632	537	1138	948	1606	1328	2099	1729	2605	2140	3110	2551	3003	3414	
30"	33"	407	352	687	577	1243	1023	1757	1435	2299	1870	2855	2316	3412	2762	3253	3699	
36"	39"	443	373	753	613	1368	1088	1938	1528	2538	1993	3104	2419	3770	2945	3468	3944	
42"	45"	472	395	807	652	1473	1163	2090	1636	2738	2134	3404	2645	4070	3156	3718	4229	
48"	51"	500	415	862	692	1578	1238	2240	1743	2938	2275	3654	2821	4370	3367	3968	4514	
51"	54"	516	428	890	713	1631	1277	2317	1799	3039	2348	3780	2913	4521	3477	4094	4657	
54"	57"	532	440	917	732	1683	1313	2391	1850	3139	2418	3904	2998	4670	3579	4218	4799	
60"	63"	567	460	982	767	1808	1378	2571	1943	3377	2539	4203	3150	5029	3761	4433	5044	

UNIT WEIGHTS (FOR 6" AND 12" ROLLER CENTERS ONLY)																			
CONVEYOR LENGTH		5'		10'		20'		30'		40'		50'		60'		70'		80'	
CONV. SURFACE	BF	6" RC	12" RC	6" RC	12" RC	6" RC	12" RC	6" RC	12" RC	6" RC	12" RC	6" RC	12" RC	6" RC	12" RC	6" RC	12" RC	6" RC	12" RC
12"	15"	299	287	482	432	848	728	1214	1064	1580	1380	1946	1699	2312	2012	2678	2328	3044	2644
18"	21"	324	297	527	467	933	813	1339	1159	1745	1505	2151	1851	2557	2197	2963	2543	3369	2889
24"	27"	349	312	572	502	1018	878	1464	1254	1910	1630	2356	2006	2802	2382	3248	2758	3694	3134
30"	33"	374	332	617	537	1103	943	1589	1349	2075	1755	2561	2161	3047	2567	3533	2973	4019	3379
36"	39"	399	348	662	563	1188	988	1714	1429	2240	1840	2766	2266	3292	2692	3818	3118	4344	3544
42"	45"	424	367	707	597	1273	1053	1839	1509	2405	1965	2971	2421	3537	2877	4103	3333	4669	3789
48"	51"	449	387	752	632	1358	1118	1964	1604	2570	2090	3176	2576	3782	3062	4388	3548	4994	4034
51"	54"	462	400	775	650	1401	1151	2027	1652	2653	2153	3279	2654	3905	3155	4531	3656	5157	4157
54"	57"	474	407	797	667	1443	1183	2089	1699	2736	2216	3381	2731	4027	3247	4673	3763	5319	4279
60"	63"	499	422	842	692	1528	1228	2214	1764	2900	2300	3586	2836	4272	3372	4958	3908	5644	4444

OPTIONAL EQUIPMENT

SPEED: Constant speed 1.5-100 FPM; DC variable speed; AC inverter variable speed. Other constant or variable speeds available. **NOTE: CAPACITY CHANGES WITH SPEED. 100 FPM MAX. WITH ROLL-TO-ROLL CHAIN DRIVE.**

FLOOR SUPPORTS: Supports, knee braces, casters and polytief supports available. See Conveyor Accessories.

ELECTRICAL CONTROLS: Magnetic starter (one direction or reversible); one direction manual starter; momentary start/stop push button station; for-ward/reversing/stop push button station; mounting and pre-wiring for units 12'-0" long and under; limit switch, photo relay; others available.

BED: 4" at 5.4 lb. and 6" at 8.2 lb. structural steel channel frame.

MOTORS: Available through 3 HP in TEFC, explosion proof, dirty duty, brake motor, 115/230/1, 575/3, etc.

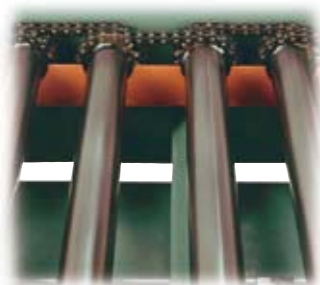

ROLLER TO ROLLER CHAIN DRIVE
(guard removed for clarity)



OPTIONAL TOP ROLLER GUARD MOUNTED DRIVE

MODEL 297CDLR HEAVY DUTY CHAIN DRIVEN LIVE ROLLER



Conveyor shown with optional supports

Model 297CDLR is specifically designed to transport heavy loads such as tote pans, castings, drums, pallet loads, etc. It is especially suited for carrying loads in the presence of oil and other such contaminants. This chain driven live roller includes 7 gauge tread rollers and structural steel frame as standard unit features.

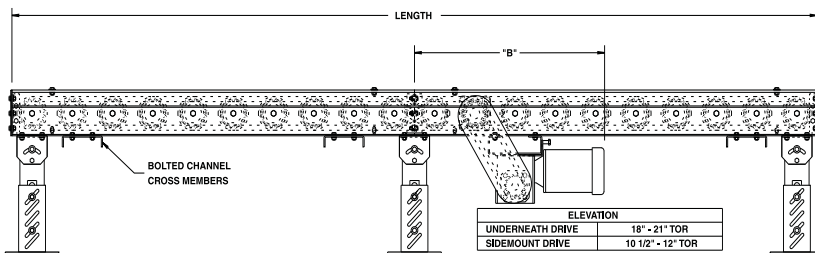
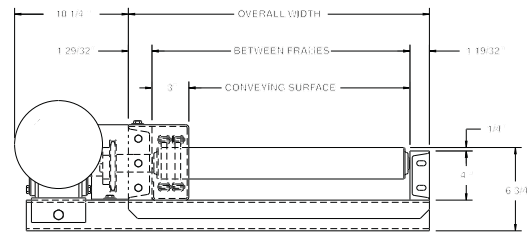
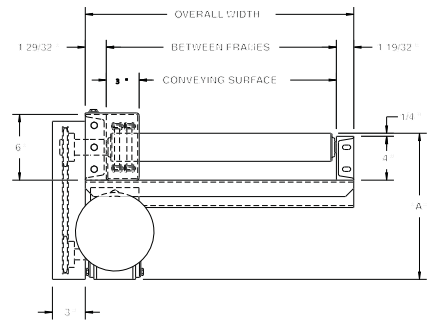

HP @ 35FPM	"A" MAX	"B" MAX
3/4	13"	38-13/16"
1	13-1/4"	39-1/8"
1-1/2	14-1/8"	39-1/8"
2	15"	40-13/16"

SPECIFICATIONS

TREAD ROLLERS: 2-9/16" dia. x 7 ga. steel rollers, model 297S with sprockets.

CHAIN DRIVE: Roller to roller with No. 60 roller chain.

CENTER DRIVE: Reversible drive either side mounted or underside mounted (specify). Main drive roller is supported by precision, heavy duty, lubricated, ball bearing units.

ROLLER CENTERS: 3", 4-1/2", 6", 9" and 12".

BED: 4" at 5.4 lbs. and 6" at 8.2 lbs. structural steel channel frame. Bed sections attached with couplings and floor supports.

SPEED: 35 FPM, constant.

BEARINGS: Precision ABEC bearings.

CHAIN GUARD: The chain drive is completely enclosed along the entire length of the conveyor.

BED LENGTHS (4-1/2" or 9" RC): Intermediate bed section lengths 3'-0", 3'-9", 4'-6", 5'-3", 6'-0", 6'-9", 7'-6", 8'-3", 9'-0" and 9'-9" increments. Minimum overall conveyor length with drive 5'-3". Maximum overall conveyor length: 58'-6" with 4-1/2" RC; 78'-0" with 9" RC.

BED LENGTHS (6" or 12" RC):

Intermediate bed section lengths are available in 1'-0" increments. Minimum overall conveyor length with drive 5'-0". Maximum overall conveyor length 80'-0".

MOTOR DRIVE: 3/4 HP, 230/460/3, 60 cycle, ODP right angle gear motor.

ELECTRICAL CONTROLS: Optional.

***NOTE 3" RC:** 3" RC are available with #40 chain on 40-14 double single sprocket sleeves.



OPTIONAL 3" RC NOW AVAILABLE
(guard removed for clarity)



SPECIFICATION TABLE

■ 4 week shipment

UNIT WEIGHTS (FOR 4-1/2" AND 9" ROLLER CENTERS ONLY)																			
CONVEYOR LENGTH		5'-3"		9'-9"		19'-6"		29'-3"		39'		48'-9"		58'-6"		68'-3"		78'	
CONV. SURFACE	BF	4-1/2" RC	9" RC	4-1/2" RC	9" RC	4-1/2" RC	9" RC	4-1/2" RC	9" RC	4-1/2" RC	9" RC	4-1/2" RC	9" RC	4-1/2" RC	9" RC	9" RC	9" RC		
12"	15"	389	299	629	494	1142	876	1635	1257	2093	1639	2603	2020	3102	2402	2783	3300		
18"	21"	414	333	709	553	1297	987	1872	1420	2401	1854	2989	2287	3564	2721	3154	3588		
24"	27"	454	354	789	609	1452	1093	2100	1577	2696	2061	3359	3287	4007	3029	3513	3997		
30"	33"	492	388	857	653	1583	1177	2292	1700	2945	2224	3671	2747	4380	3271	3794	4318		
36"	39"	536	418	936	708	1736	1282	2517	1855	3237	2430	4037	3002	4818	3576	4149	4723		
42"	45"	573	446	1013	761	1885	1384	2736	2006	3520	2630	4392	3251	5243	3874	4496	5119		
48"	51"	620	479	1090	814	2034	1481	2955	2147	3805	2814	4749	3480	5670	4147	4813	5480		
51"	54"	640	491	1130	841	2109	1532	3065	2223	3948	2914	4927	3605	5883	4296	4987	5678		
54"	57"	662	507	1167	867	2183	1583	3174	2298	4090	3014	5105	3729	6096	4445	5160	5876		
60"	63"	701	537	1246	922	2336	1688	3399	2453	4380	3219	5470	3984	6532	4750	5530	6281		

UNIT WEIGHTS (FOR 6" AND 12" ROLLER CENTERS ONLY)																			
CONVEYOR LENGTH		5'		10'		20'		30'		40'		50'		60'		70'		80'	
CONV. SURFACE	BF	6" RC	12" RC	6" RC	12" RC	6" RC	12" RC	6" RC	12" RC	6" RC	12" RC	6" RC	12" RC	6" RC	12" RC	6" RC	12" RC		
12"	15"	333	278	549	439	982	769	1415	1099	1848	1429	2281	1759	2714	2039	3147	2419	3850	2749
18"	21"	370	315	618	488	1115	859	1612	1228	2109	1598	2606	1968	3103	2338	3600	2708	4097	3078
24"	27"	405	350	684	534	1242	944	1800	1354	2358	1764	2916	2174	3474	2584	4032	2994	4590	3404
30"	33"	435	380	738	568	1345	1008	1952	1448	2559	1888	3166	2328	3773	2768	4380	3208	4987	3648
36"	39"	470	415	803	613	1470	1093	2137	1573	2804	2053	3471	2533	4138	3013	4805	3493	5472	3973
42"	45"	504	449	866	656	1591	1176	2316	1696	3041	2216	3766	2736	4491	3256	5216	3776	5941	4296
48"	51"	538	483	929	699	1712	1249	2495	1799	3278	2349	4061	2899	4844	3449	5627	3999	6410	4549
51"	54"	554	499	961	721	1773	1291	2585	1861	3397	2431	4209	3001	5021	3571	5833	4141	6645	4711
54"	57"	572	517	992	742	1833	1332	2674	1922	3516	2512	4356	3102	5197	3692	6038	4282	6879	4872
60"	63"	607	552	1057	787	1958	1417	2859	2047	3760	2677	4661	3307	5562	3937	6463	4567	7364	5197

OPTIONAL EQUIPMENT

SPEED: Constant speed 1.5-100 FPM; DC variable speed; AC inverter variable speed. Other constant or variable speeds available. **NOTE: CAPACITY CHANGES WITH SPEED. 100 FPM MAX. WITH ROLL-TO-ROLL CHAIN DRIVE.**

MOTORS: Available through 3 HP in TEFC, explosion proof, dirty duty, brake motor, 115/230/1, 575/3, etc.

FLOOR SUPPORTS: Supports, knee braces, casters and polytier supports available. See Conveyor Accessories.

ELECTRICAL CONTROLS: Magnetic starter (one direction or reversible); one direction manual starter; momentary start/stop push button station; forward/reversing/stop push button station; mounting and pre-wiring for units 12'-0" long and under; limit switch, photo relay; others available.

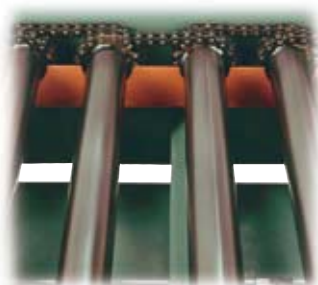

ROLLER TO ROLLER CHAIN DRIVE
(guard removed for clarity)



OPTIONAL TOP ROLLER GUARD MOUNTED DRIVE

MODEL 3530CDLR HEAVY DUTY CHAIN DRIVEN LIVE ROLLER

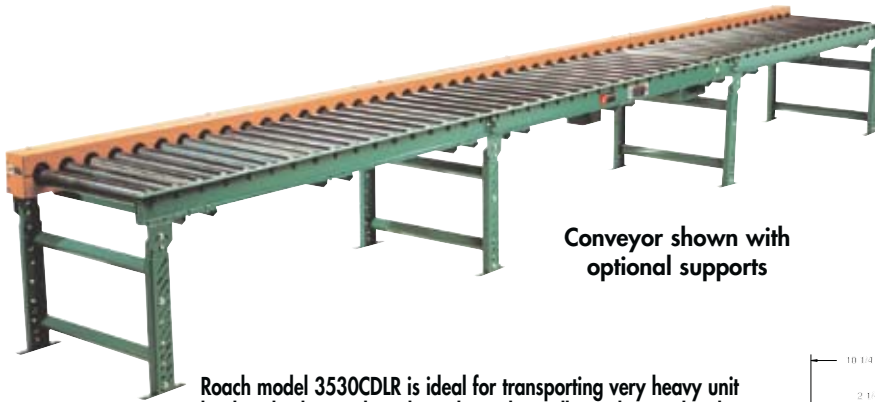

Conveyor shown with optional supports

Roach model 3530CDLR is ideal for transporting very heavy unit loads. This heavy duty chain driven live roller is designed with heavy .300 wall steel rollers, larger size roller chain and heavy duty structural frame and supports for applications demanding ultra-durable construction for longevity and durability.

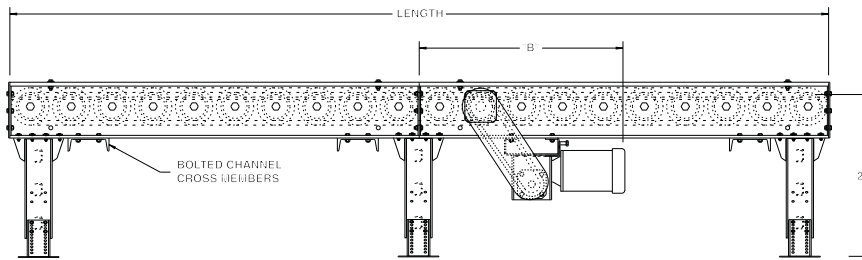
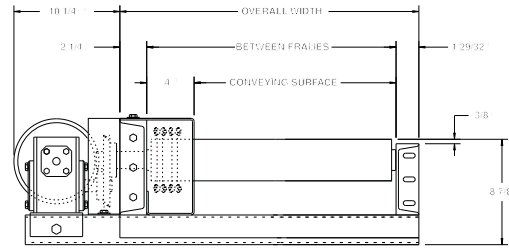
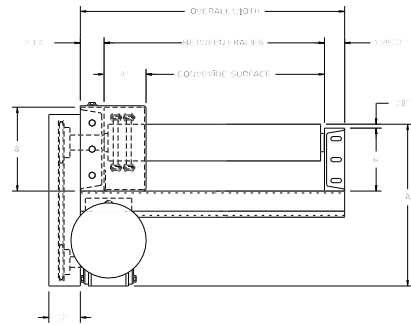

HP @ 35FPM	"A"	"B" MAX
3/4	16"	38-13/16"
1	16-1/4"	39-1/8"
1-1/2	17-1/8"	39-1/8"
2, 3	18-1/2"	40-13/16"
2	18-1/2"	41-13/16"

SPECIFICATIONS

TREAD ROLLERS: 3-1/2" dia. x .300 wall steel, model 3530S with sprockets.

CHAIN GUARD: The chain drive is completely enclosed along the entire length of the conveyor.

CENTER DRIVE: Reversible drive either side mounted or underneath mounted (specify). Main drive roller is supported by precision, heavy duty, lubricated, ball bearing units.

BEARINGS: Precision ABEC bearings.

BED LENGTHS (6" RC, #60 CHAIN AND 12" RC, #80 CHAIN): Intermediate bed section lengths 3'-0", 4'-0", 5'-0", 6'-0", 7'-0", 8'-0", 9'-0" and 10'-0" increments. Minimum overall conveyor length with drive 5'-0". Maximum overall conveyor length 80'-0".

BED LENGTHS (7-1/2" RC, #80 CHAIN): Intermediate bed section lengths 3'-1-1/2", 3'-9", 4'-4-1/2", 5'-0", 5'-7-1/2", 6'-3", 6'-10-1/2", 7'-6", 8'-1-1/2", 8'-9", 9'-4-1/2" and 10'-0". Minimum overall conveyor length with drive 5'-0". Maximum overall conveyor length 80'-0".

ROLLER CENTERS: 6" with No. 60 chain; 7-1/2" and 12" with No. 80 chain.

CHAIN DRIVE: Roller to roller with No. 60 or No. 80 roller chain.

SPEED: 35 FPM constant.

BED: 6" at 8.2 lbs. and 8" at 11.5 lbs. structural steel frame. Bed sections attached with couplings and floor supports.

MOTOR DRIVE: 3/4 HP, 230/460/3, 60 cycle, ODP right angle gear motor.

ROLLER CAPACITY: 2500 lbs. per roller.

ELECTRICAL CONTROLS: Optional.



SPECIFICATION TABLE

■ 4 week shipment

CONVEYOR LENGTH				10'	20'	30'	40'	50'	60'	70'	80'
CONV. SURFACE	BF	RC	CHAIN SIZE	UNIT WEIGHTS (lbs.)							
35"	39"	6"	60	1453	2873	4293	5713	7133	8553	9973	11393
		7-1/2"	80	1337	2950	4563	6176	7789	9402	11015	12628
		12"	80	990	1950	2910	3870	4830	5790	6750	7710
41"	45"	6"	60	1605	3179	4753	6327	7901	9475	11049	12623
		7-1/2"	80	1472	3165	4858	6551	8244	9937	11630	13323
		12"	80	1074	2104	3134	4164	5194	6224	7254	8284
47"	51"	6"	60	1757	3485	5213	6941	8669	10397	12125	13853
		7-1/2"	80	1607	3380	5153	6926	8699	10472	12245	14018
		12"	80	1159	2269	3379	4489	5599	6709	7819	8929
53"	57"	6"	60	1909	3791	5673	7555	9437	11319	13201	15083
		7-1/2"	80	1743	3596	5449	7302	9155	11008	12861	14714
		12"	80	1243	2423	3603	4783	5963	7143	8323	9503

OPTIONAL EQUIPMENT

SPEED: Constant speed 1.5-100 FPM; DC variable speed; AC inverter variable speed. Other constant or variable speeds available. **NOTE: CAPACITY CHANGES WITH SPEED. 100 FPM MAX. WITH ROLL-TO-ROLL CHAIN DRIVE.**

FLOOR SUPPORTS: Supports and knee braces available. See Conveyor Accessories.

ELECTRICAL CONTROLS: Magnetic starter (one direction or reversible); one direction manual starter; momentary start/stop push button station; forward/reversing/stop push button station; mounting and pre-wiring for units 12'-0" long and under; limit switch, photo relay; others available.

MOTORS: Available through 5 HP in TEFC, explosion proof, dirty duty, brake motor, 115/230/1, 575/3, etc.

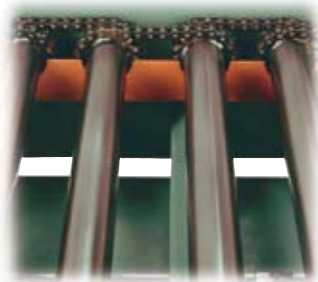

ROLLER TO ROLLER CHAIN DRIVE
(guard removed for clarity)



OPTIONAL TOP ROLLER GUARD MOUNTED DRIVE



MODEL 251CDLRC HEAVY DUTY CHAIN DRIVEN LIVE ROLLER CURVE



Conveyor shown with optional supports

251CDLRC, heavy duty chain driven live roller curve, transports heavy unit loads. Heavy castings, drums and other loads not requiring product orientation may be effectively conveyed on this conveyor.

SPECIFY MODEL NUMBER PER EXAMPLE

251CDLRC-39-90-L

251CDLRC-(between frames)-(degree)-(left or right)

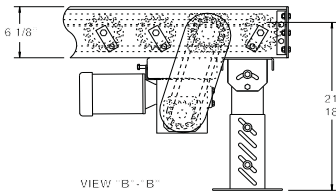
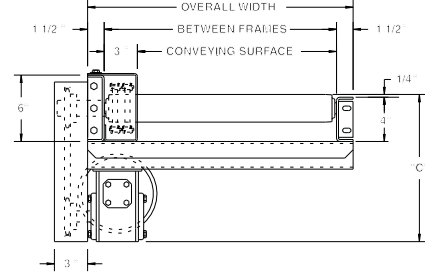

DETERMINING DRIVE LOCATION

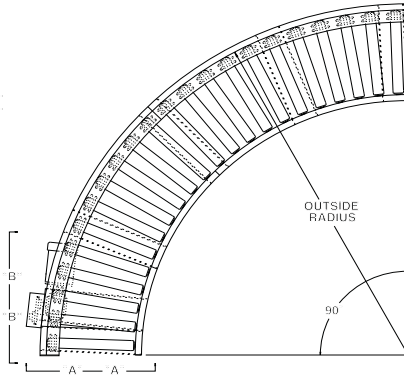
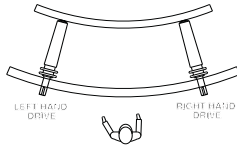

UNIT		90°		45°		
BF	CONV SURFACE	OUTSIDE RADIUS	QTY. RLRS.	WT (lbs.)	QTY. RLRS.	WT (lbs.)
15"	12"	7'-1-1/2"	22	624	11	347
21"	18"	7'-1-1/2"	22	672	11	374
27"	24"	7'-1-1/2"	22	721	11	401
33"	30"	7'-1-1/2"	22	769	11	428
39"	36"	7'-1-1/2"	22	815	11	454
45"	42"	10'-3-3/4"	32	1244	16	672
51"	48"	10'-3-3/4"	32	1383	16	744
57"	54"	10'-3-3/4"	32	1531	16	827
63"	60"	10'-3-3/4"	32	1680	16	909

SPECIFICATIONS

TREAD ROLLERS: 2-1/2" dia. x 11 ga. steel, model 251S with sprockets.

CHAIN DRIVE: Roller to roller with No. 60 circular roller chain.

END DRIVE: Reversible drive either side mounted or underside (specify). Main drive roller is supported by precision, heavy duty, lubricated, ball bearing units.

BEARINGS: Precision ABEC bearings.

ROLLER CENTERS: 6" RC measured at outside radius of curve.

MOTOR DRIVE: 3/4 HP, 230/460/3, 60 cycle, ODP right angle gear motor.

SPEED: 35 FPM, constant.

BED: 6" x 1-1/2" x 7 ga. and 4" x 1-1/2" x 7 ga. formed steel channel frame.

CHAIN GUARD: The chain drive is enclosed, top and bottom, along the entire length of the conveyor.

DRIVE LOCATION: Drive located on outside of curve. Specify right hand drive or left hand drive (drive hand determined with reference point located at outside of curve).

ELECTRICAL CONTROLS: Optional.

HP @ 35FPM	"C"
3/4	13"
1	13-1/4"
1-1/2	14-1/8"
2	15"

OPTIONAL EQUIPMENT

BED: Rollers on 4-1/2" centers on outside radius.

SPEED: Constant speed 1.5-60 FPM; DC variable speed; AC inverter variable speed. Other constant or variable speeds available.

NOTE: CAPACITY CHANGES WITH SPEED. 100 FPM MAX. WITH ROLLER-TO-ROLLER CHAIN DRIVE.

MOTORS: Available through 3 HP in TEFC, explosion proof, dirty duty, 115/230/1, 575/3, etc.

FLOOR SUPPORTS: Supports, knee braces, casters, and polytief supports available. See Conveyor Accessories.

*NOTE: Orientation of product may be affected because of straight rollers in curve. To maintain orientation, use tapered roller curve.

■ 4 week shipment



MODEL 297CDLRC HEAVY DUTY CHAIN DRIVEN LIVE ROLLER CURVE



Conveyor shown with optional supports

Model 297CDLRC features structural steel channel frames for conveying heavy unit loads. Heavy castings, drums and numerous other loads not requiring product orientation may be transported on this heavy duty chain driven live roller curve.

SPECIFY MODEL NUMBER PER EXAMPLE
297CDLRC-57-45-R
 297CDLRC-(between frames)-(degree)-(left or right)

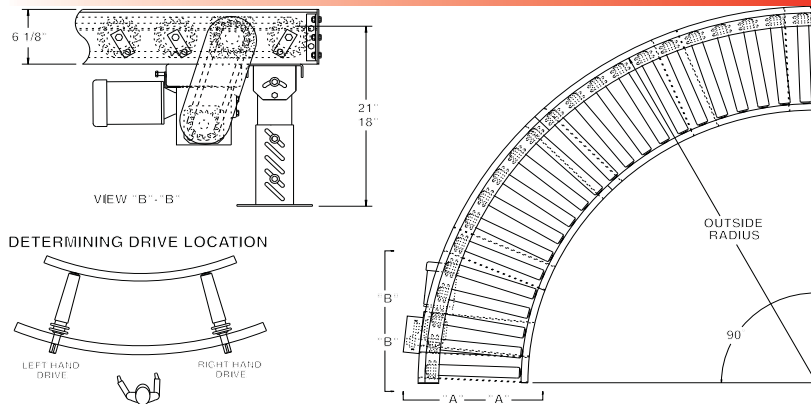
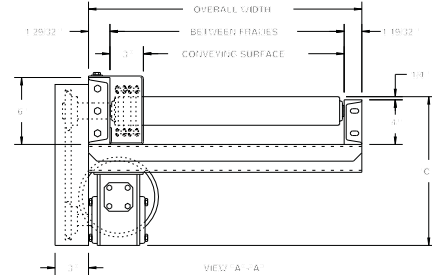

UNIT	90°		45°			
	BF	CONV. SURFACE	QTY. RLRs.	WT (lbs.)	QTY. RLRs.	WT (lbs.)
15"	12"	7'-1-1/2"	22	736	11	421
21"	18"	7'-1-1/2"	22	846	11	495
27"	24"	7'-1-1/2"	22	956	11	540
33"	30"	7'-1-1/2"	22	1066	11	750
39"	36"	7'-1-1/2"	22	1176	11	811
45"	42"	10'-3-3/4"	32	1625	16	872
51"	48"	10'-3-3/4"	32	1735	16	965
57"	54"	10'-3-3/4"	32	1845	16	1026

SPECIFICATIONS

TREAD ROLLERS: 2-9/16" dia. x 7 ga. steel, model 297S with sprockets.*

CHAIN DRIVE: Roller to roller with No. 60 circular roller chain.

END DRIVE: Reversible drive, either side mounted or underside (specify). Main drive roller is supported by precision, heavy duty, lubricated, ball bearing units.

CHAIN GUARD: Chain drive is enclosed, top and bottom, along entire length of conveyor.

ROLLER CENTERS: 6" RC measured at outside radius of curve.

BED: 4" at 5.4 lbs. and 6" at 8.2 lbs. structural steel channel frame.

BEARINGS: Precision ABEC bearings.

MOTOR DRIVE: 3/4 HP, 230/460/3, 60 cycle, ODP right angle gear motor.

SPEED: 35 FPM, constant.

DRIVE LOCATION: Drive located on outside of curve. Specify right hand drive or left hand drive (drive hand determined with reference point located at outside of curve).

ELECTRICAL CONTROLS: Optional.

HP @ 35FPM	"C"
3/4	13"
1	13-1/4"
1-1/2	14-1/8"
2	15"

OPTIONAL EQUIPMENT

BED: Rollers on 4-1/2" centers on outside radius.

SPEED: Constant speed 1.5-60 FPM; DC variable speed; AC inverter variable speed. Other constant or variable speeds available.

NOTE: CAPACITY CHANGES WITH SPEED. 100 FPM MAX. WITH ROLLER-TO-ROLLER CHAIN DRIVE.

MOTORS: Available through 3 HP in TEFC, explosion proof, dirty duty, 115/230/1, 575/3, etc.

FLOOR SUPPORTS: Supports, knee braces, casters, and polytier supports available. See Conveyor Accessories.

*NOTE: Orientation of product may be affected because of straight rollers in curve. To maintain orientation, use tapered roller curve.



■ 4 week shipment

MODEL 351TCDLRC HEAVY DUTY TAPERED ROLLER CHAIN DRIVEN LIVE ROLLER CURVE



Conveyor shown with side mounted drive and optional supports

351TCDLRC is a true taper heavy duty chain driven live roller curve. Ideal for conveying pallets or other heavy unit loads, this conveyor features "true taper" to maintain product orientation throughout the curve.

SPECIFY MODEL NUMBER PER EXAMPLE
351TCDLRC-51-90-R
 351TCDLRC-(between frames)-(degree)-(left or right)

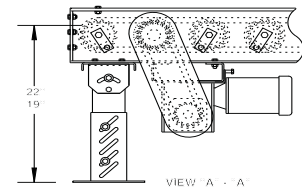
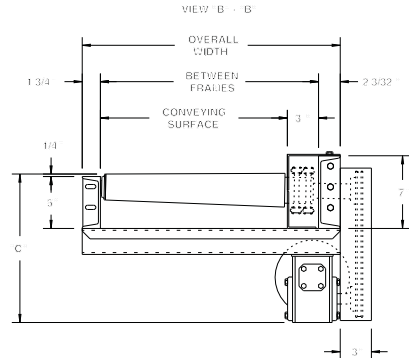

DETERMINING DRIVE LOCATION

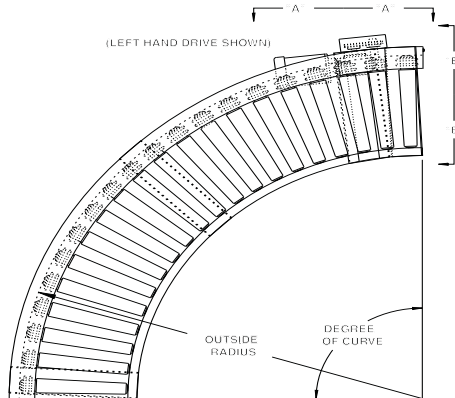
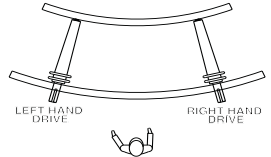

UNIT	90°		45°				
	BF	WT (lbs.)	BF	WT (lbs.)			
21"	3-1/4"	2-1/2"	6-6"	20	778	10	423
27"	3-1/2"	2-1/2"	7'-1-1/2"	22	966	11	524
33"	3-3/4"	2-1/2"	7'-9-1/4"	24	1192	12	644
39"	4"	2-1/2"	8'-4-3/4"	26	1460	13	787
45"	4-1/4"	2-1/2"	8'-4-3/4"	26	1523	13	801
51"	4-1/2"	2-1/2"	9-1/2"	28	1889	14	990
57"	4-3/4"	2-1/2"	9'8"	30	2307	15	1210
63"	5"	2-1/2"	10-3-3/4"	32	2789	16	1464

SPECIFICATIONS

TREAD ROLLERS: Heavy duty 11 ga. tapered rollers, model 351T with sprockets, for true taper effect. See chart, upper right corner for roller dia.

CHAIN DRIVE: Roller to roller with No. 60 circular roller chain.

END DRIVE: Reversible drive either side mounted or underside (specify). Main drive roller is supported by precision, heavy duty, lubricated, ball bearing units.

ROLLER CENTERS: 6" RC measured at outside radius of curve.

SPEED: 35 FPM, constant.

BED: 5" at 6.7 lbs. and 7" at 9.8 lbs. structural steel channel frame.

BEARINGS: Precision ABEC bearings.

CHAIN GUARD: The chain drive is enclosed, top and bottom, along the entire length of the conveyor.

MOTOR DRIVE: 3/4 HP, 230/460/3, 60 cycle, ODP right angle gear motor.

DRIVE LOCATION: Drive located on outside of curve. Specify right hand drive or left hand drive (drive hand determined with reference point located at outside of curve).

ELECTRICAL CONTROLS: Optional.

HP @ 35FPM	"C"
3/4	15"
1	15-1/4"
1-1/2	16-1/8"
2	17"

OPTIONAL EQUIPMENT

BED: Rollers on 4-1/2" centers on outside radius for 21"-39" BF.

FLOOR SUPPORTS: Supports available. See Conveyor Accessories.

SPEED: Constant speed 1.5-60 FPM; DC variable speed; AC inverter variable speed. Other constant or variable speeds available.

NOTE: CAPACITY CHANGES WITH SPEED. 100 FPM MAX. WITH ROLLER-TO-ROLLER CHAIN DRIVE.

MOTORS: Available through 3 HP in TEFC, explosion proof, dirty duty, 115/230/1, 575/3, etc.

