

MODEL 725TB TROUGH BED BELT CONVEYOR

24 HOUR SHIPMENTS INCLUDE ALL 1-FOOT INCREMENTS 5'-0" TO 100'-0"



Conveyor shown with optional supports

725TB trough bed belt conveyor is ideal for handling chips, slugs, scrap wood, paper waste, boxes, packages and cartons. The troughed frame design offers integral guard rails for many trash conveyor applications.

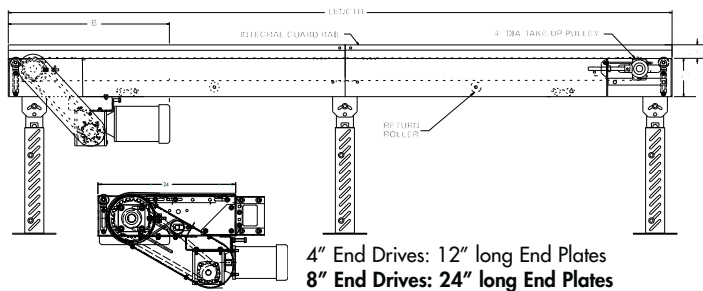
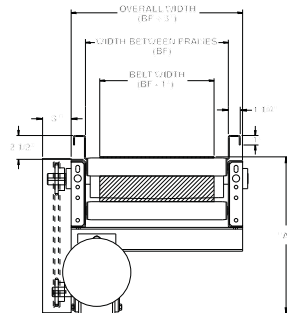

4" End Drives: 12" long End Plates
8" End Drives: 24" long End Plates

HP@ 60 FPM	"A" MAX		"B" MAX	
	4" DRV.	8" DRV.	4" DRV.	8" DRV.
1/3	16-5/8"	16-5/8"	27-3/32"	33-3/32"
1/2	16-5/8"	16-5/8"	27-3/32"	33-3/32"
3/4	17"	17"	27-23/32"	33-23/32"
1	17-1/4"	17-1/4"	28-15/32"	34-15/32"
1-1/2	18-1/8"	18-1/8"	31-3/32"	37-3/32"
2	19"	19"	32-3/32"	38-3/32"

SPECIFICATIONS

BELTING: PVC-120 black.

DRIVE PULLEY: 4" dia. with 1-3/16" dia. shaft or 8" dia. with 1-7/16" dia. shaft, both machine crowned and fully lagged.

TAIL PULLEY: 4" dia., machine crowned, with 1-3/16" dia. shaft.

END DRIVE: Allows one-direction (unit) operation; add optional center drive for reversible application.

TAKE-UP: Screw type unit at tail pulley provides 12" belt take-up.

SAFETY POP-OUT ROLLER: Standard on both ends, 1.9" dia. x 16 ga. steel roller, model 196S.

BEARINGS: All pulley bearings are precision, heavy duty, lubricated, ball bearing units with cast iron housings.

BED: 7" deep x 12 ga. box type bed with bed pan braces (all widths) and with 2-1/2" deep x 12 ga. formed trough with formed flanges on sides to provide extra strength.

MOTOR DRIVE: 1/3 HP, 230/460/3, 60 cycle, ODP right angle gear motor.

ROLLER CHAIN: Drive pulley is driven by No. 50 roller chain for 1-1/2 HP or less and No. 60 chain on larger drives. Chain take-up provided on motor base.

RETURN ROLLERS: 1.9" dia.

⚠ WARNING

Prevent pinch points that exist when belt conveyors are permanently attached to other conveyors or equipment!



SPECIFICATION TABLE

50'-0" lengths and under are equipped with 4" dia. drive pulley; over 50'-0" includes 8" dia. drive pulley

■ 24 hour shipment ■ 2 week shipment

CONVEYOR LENGTH		10'	20'	30'	40'	50'	60'	70'	80'	90'	100'	DEDUCT
BELT	BED	UNIT WEIGHTS (lbs.)										PER FOOT
6"	7"	305	477	649	821	993	1166	1338	1510	1682	1854	17
12"	13"	360	569	778	988	1197	1406	1615	1825	2034	2243	21
18"	19"	415	661	907	1154	1400	1646	1893	2139	2386	2632	25
24"	25"	469	753	1036	1320	1603	1887	2170	2454	2737	3021	28
30"	31"	524	845	1165	1486	1807	2127	2448	2769	3089	3410	32
36"	37"	579	937	1295	1652	2010	2368	2726	3083	3441	3799	36

OPTIONAL EQUIPMENT

BELTING: Black PVC ruff-top; 3-ply brown neoprene ruff-top; PVC-120 white food grade COS; PVC-150 black COS; 3-ply CN 40 urethane cover. Consult factory for other belting.

CENTER DRIVE: Reversible drive with integral belt take-up of 24". Specify location. Center drive option available on units 6'-0" long and above.

SIDE MOUNTED END DRIVE: OVERHEAD END DRIVE: Provides minimum conveyor height of 8" TOB (4" dia. drive pulley); 10" TOB (8" dia. drive pulley).

BELT SPEED: Constant speed 10-120 FPM; DC variable speed; AC inverter variable speed. Other constant or variable speeds available.

NOTE: CAPACITY CHANGES WITH SPEED.

AUXILIARY TAKE-UP: Provides 24" of belt take-up. Specify location. See Power Accessories.

UNDERTRUSSED BED: Available to provide clearance underneath unit at bed joint locations. Specify location for undertrussing and desired clearance underneath unit. Consult factory.

MOTORS: Available through 3 HP in TEFC, explosion proof, dirty duty, brake motor, 115/230/1, 575/3, etc.

FLOOR SUPPORTS: Supports, knee braces, casters and polytier supports available. See Conveyor Accessories.

CEILING HANGERS: 5/8" dia. threaded rod with hardware to attach rods to conveyor. Provides 6' clearance between ceiling and TOB (furnished in place of floor supports). See Conveyor Accessories.

GUARD RAILS: Available in 2", 4" and 6" heights (model FSG) to attach to troughed frame to increase trough depth. See Conveyor Accessories.

ELECTRICAL CONTROLS: Magnetic starter (one direction or reversible); One direction manual starter; Momentary start/stop push button station; Forward/reversing /stop push button station. Mounting and pre-wiring for units up to 12' long.



DETAIL OF INTERMEDIATE BED SECTION



OPTIONAL OVERHEAD MOUNTED DRIVE



MODEL 700SB MEDIUM DUTY SLIDER BED BELT CONVEYOR

24 HOUR SHIPMENTS INCLUDE ALL 1-FOOT INCREMENTS 5'-0" TO 100'-0"



Conveyor shown with optional supports

Slider bed belt conveyors remain the most popular of all powered conveyors, providing an economical means of transporting goods for packing, testing, inspecting and various assembly line operations

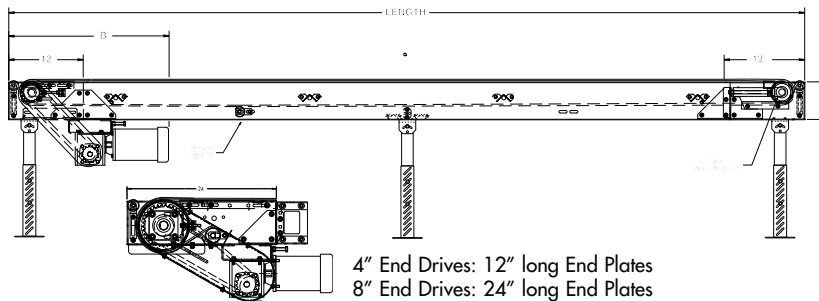
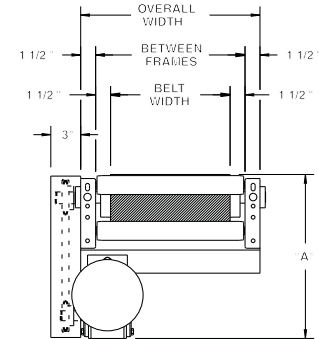

HP @ 60 FPM	"A" MAX		"B" MAX	
	4" DRV.	8" DRV.	4" DRV.	8" DRV.
1/3	16-5/8"	16-5/8"	27-3/32"	33-3/32"
1/2	16-5/8"	16-5/8"	27-3/32"	33-3/32"
3/4	17"	17"	27-23/32"	33-23/32"
1	17-1/4"	17-1/4"	28-15/32"	34-15/32"
1-1/2	18-1/8"	18-1/8"	31-3/32"	37-3/32"
2	19"	19"	32-3/32"	38-3/32"

SPECIFICATIONS

BELTING: PVC-120 black.

DRIVE PULLEY: 4" dia. with 1-3/16" dia. shaft or 8" dia. with 1-7/16" dia. shaft, both machine crowned and fully lagged.

TAIL PULLEY: 4" dia., machine crowned, with 1-3/16" dia. shaft.

END DRIVE: Allows one-direction (unit) operation; add optional center drive for reversible application.

TAKE-UP: Screw type unit at tail pulley provides 12" belt take-up.

SAFETY POP-OUT ROLLER: Standard on both ends, 1.9" dia. x 16 ga. steel roller, model 196S.

BEARINGS: All pulley bearings are precision, heavy duty, lubricated, ball bearing units with cast iron housings.

BED: 7" x 1-1/2" x 12 ga. channel frame with 14 ga. slider bed.

BELT SPEED: 60 FPM, constant.

MOTOR DRIVE: 1/3 HP, 230/460/3, 60 cycle, ODP right angle gear motor.

ROLLER CHAIN: Drive pulley is driven by No. 50 roller chain for 1-1/2 HP or less and No. 60 chain on larger drives. Chain take-up provided on motor base.

RETURN ROLLERS: 1.9" dia. x 16 ga. steel, model 196S, adjustable.

ELECTRICAL CONTROLS: Optional.

⚠ WARNING

Prevent pinch points that exist when belt conveyors are permanently attached to other conveyors or equipment!



SPECIFICATION TABLE

50'-0" lengths and under are equipped with 4" dia. drive pulley; over 50'-0" includes 8" dia. drive pulley

■ 24 hour shipment ■ 2 week shipment

CONVEYOR LENGTH		10'	20'	30'	40'	50'	60'	70'	80'	90'	100'	DEDUCT
BELT	BED	UNIT WEIGHTS (lbs.)										PER FOOT
6"	9"	260	389	518	647	776	904	1033	1162	1291	1420	13
12"	15"	315	482	650	818	986	1154	1322	1490	1657	1825	17
18"	21"	369	576	783	990	1196	1403	1610	1817	2024	2230	21
24"	27"	424	670	915	1161	1407	1653	1898	2144	2390	2636	25
30"	33"	478	763	1048	1333	1617	1902	2187	2471	2756	3041	29
36"	39"	533	857	1180	1504	1828	2151	2475	2799	3122	3446	32

OPTIONAL EQUIPMENT

BELTING: Black PVC ruff-top; 3-ply brown neoprene ruff-top; PVC-120 white food grade COS; PVC-150 black COS; 3-ply CN 40 urethane cover. Consult factory for other belting.

CENTER DRIVE: Reversible drive with integral belt take-up of 24". Specify location. Center drive option available on units 6'-0" long and above.

SIDE MOUNTED END DRIVE: Provides minimum conveyor height of 10" TOB (4" dia. drive pulley); 12" TOB (8" dia. drive pulley).

OVERHEAD END DRIVE: Provides minimum conveyor height of 8" TOB (4" dia. drive pulley); 10" TOB (8" dia. drive pulley).

NOSE-OVER: Provides smooth transition from incline to horizontal position. Single nose-over adjusts 0-20°; double nose-over adjusts 0-35°. Feeders also available. See Power Accessories.

AUXILIARY TAKE-UP: Provides 24" of belt take-up. Specify location. See Power Accessories.

SIDE TABLES: Available in 9", 15" and 21" widths (14 ga.) one or both sides. See Power Accessories.

UNDERTRUSSED BED: Available to provide clearance underneath unit at bed joint locations. Specify location for undertrussing and desired clearance underneath unit. Consult factory.

CEILING HANGERS: 5/8" dia. threaded rod with hardware to attach rods to conveyor. Provides 6' clearance between ceiling and TOB (furnished in place of floor supports). See Conveyor Accessories.

BELT SPEED: Constant speed 10-120 FPM; DC variable speed; AC inverter variable speed. Other constant or variable speeds available.

NOTE: CAPACITY CHANGES WITH SPEED.

FLOOR SUPPORTS: Supports, knee braces, casters and polytier supports available. See Conveyor Accessories.

GUARD RAILS: 1-3/4" x 1" formed channel (model GC), adjusts horizontally to 10" wider than belt and vertically to 6" above belt; formed steel fixed (model FSG in 2", 4", 6", 8", 12", and 18" heights; fixed channel (model FC); 1-1/2" angle (model GA1-1/2). See Conveyor Accessories.

MOTORS: Available through 3 HP in TEFC, explosion proof, dirty duty, brake motor, 115/230/1, 575/3, etc.

ELECTRICAL CONTROLS: Magnetic starter (one direction or reversible); One direction manual starter; Momentary start/stop push button station; Forward/reversing /stop push button station. Mounting and pre-wiring for units up to 12' long.



OPTIONAL DC VARIABLE SPEED CONTROLLER



OPTIONAL CENTER DRIVE



MODEL 700BSB MEDIUM DUTY BOX STYLE SLIDER BED BELT CONVEYOR

24 HOUR SHIPMENTS INCLUDE ALL 1-FOOT INCREMENTS 5'-0" TO 100'-0"



Conveyor shown with optional supports

Model 700BSB features a box style slider bed which offers a smooth work surface, ideal for workers stationed beside this conveyor. The 700BSB is an economical choice for tasks such as packing, testing and inspecting.

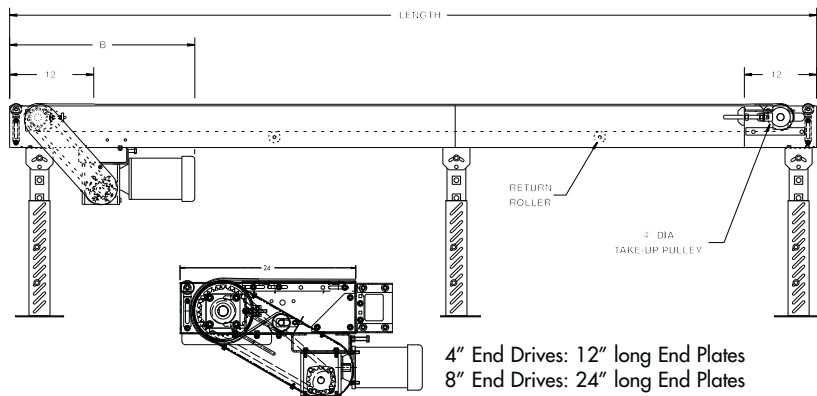
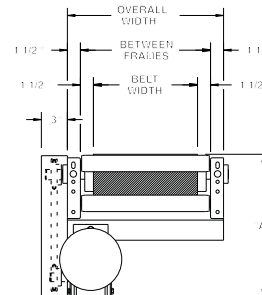

4" End Drives: 12" long End Plates
8" End Drives: 24" long End Plates

HP @ 60 FPM	"A" MAX		"B" MAX	
	4" DRV.	8" DRV.	4" DRV.	8" DRV.
1/3	16-5/8"	16-5/8"	27-3/32"	33-3/32"
1/2	16-5/8"	16-5/8"	27-3/32"	33-3/32"
3/4	17"	17"	27-23/32"	33-23/32"
1	17-1/4"	17-1/4"	28-15/32"	34-15/32"
1-1/2	18-1/8"	18-1/8"	31-3/32"	37-3/32"
2	19"	19"	32-3/32"	38-3/32"

SPECIFICATIONS

BELTING: PVC-120 black.

DRIVE PULLEY: 4" dia. with 1-3/16" dia. shaft or 8" dia. with 1-7/16" dia. shaft, both machine crowned and fully lagged.

TAIL PULLEY: 4" dia., machine crowned, with 1-3/16" dia. shaft.

END DRIVE: Allows one-direction (unit) operation; add optional center drive for reversible application.

SAFETY POP-OUT ROLLER: Standard on both ends, 1.9" dia. x 16 ga. steel roller, model 196S.

TAKE-UP: Screw type unit at tail pulley provides 12" belt take-up.

BED: 7" deep x 12 ga. box type construction.

BEARINGS: All pulley bearings are precision, heavy duty, lubricated, ball bearing units with cast iron housings.

RETURN ROLLERS: 1.9" dia. x 16 ga. steel, model 196S, adjustable.

MOTOR DRIVE: 1/3 HP, 230/460/3, 60 cycle, ODP right angle gear motor.

ROLLER CHAIN: Drive pulley is driven by No. 50 roller chain for 1-1/2 HP or less and No. 60 chain on larger drives. Chain take-up provided on motor base.

BELT SPEED: 60 FPM, constant.

ELECTRICAL CONTROLS: Optional.

WARNING

Prevent pinch points that exist when belt conveyors are permanently attached to other conveyors or equipment!



SPECIFICATION TABLE

■ 24 hour shipment ■ 2 week shipment

50'-0" lengths and under are equipped with 4" dia. drive pulley; over 50'-0" includes 8" dia. drive pulley

CONVEYOR LENGTH		10'	20'	30'	40'	50'	60'	70'	80'	90'	100'	DEDUCT
BELT	BED	UNIT WEIGHTS (lbs.)										PER FOOT
6"	9"	267	391	515	640	764	888	1012	1137	1261	1385	12
12"	15"	325	497	669	840	1012	1183	1355	1527	1698	1870	17
18"	21"	384	603	822	1041	1260	1479	1698	1917	2136	2355	22
24"	27"	442	709	975	1241	1508	1774	2040	2307	2573	2839	27
30"	33"	501	814	1128	1442	1756	2069	2383	2697	3010	3324	31
36"	39"	559	920	1281	1642	2003	2365	2726	3087	3448	3809	36

OPTIONAL EQUIPMENT

BELTING: Black PVC ruff-top; 3-ply brown neoprene ruff-top; PVC-120 white food grade COS; PVC-150 black COS; 3-ply CN 40 urethane cover. Consult factory for other belting.

CENTER DRIVE: Reversible drive with integral belt take-up of 24". Specify location. Center drive option available on units 6'-0" long and above.

SIDE MOUNTED END DRIVE: Provides minimum conveyor height of 10" TOB (4" dia. drive pulley); 12" TOB (8" dia. drive pulley).

OVERHEAD END DRIVE: Provides minimum conveyor height of 8" TOB (4" dia. drive pulley); 10" TOB (8" dia. drive pulley).

AUXILIARY TAKE-UP: Provides 24" of belt take-up. Specify location. See Power Accessories.

NOSE-OVER: Provides smooth transition from incline to horizontal position. Single nose-over adjusts 0-20°; double nose-over adjusts 0-35°. Feeders also available. See Power Accessories.

UNDERTRUSSED BED: Available to provide clearance underneath unit at bed joint locations. Specify location for undertrussing and desired clearance underneath unit. Consult factory.

SIDE TABLES: Available in 9", 15" and 21" widths (14 ga.) one or both sides. See Power Accessories.

FLOOR SUPPORTS: Supports, knee braces, casters and polytier supports available. See Conveyor Accessories.

CEILING HANGERS: 5/8" dia. threaded rod with hardware to attach rods to conveyor. Provides 6' clearance between ceiling and TOB (furnished in place of floor supports). See Conveyor Accessories.

GUARD RAILS: 1-3/4" x 1" formed channel (model GC), adjusts horizontally to 10" wider than belt and vertically to 6" above belt; formed steel fixed (model FSG in 2", 4", 6", 8", 12", and 18" heights; fixed channel (model FC); 1-1/2" angle (model GA1-1/2). See Conveyor Accessories.

BELT SPEED: Constant speed 10-120 FPM; DC variable speed; AC inverter variable speed. Other constant or variable speeds available.

NOTE: CAPACITY CHANGES WITH SPEED.

MOTORS: Available through 3 HP in TEFC, explosion proof, dirty duty, brake motor, 115/230/1, 575/3, etc.

ELECTRICAL CONTROLS: Magnetic starter (one direction or reversible); One direction manual starter; Momentary start/stop push button station; Forward/reversing /stop push button station. Mounting and pre-wiring for units up to 12' long.



OPTIONAL CENTER DRIVE



MODEL 450BOS BOX STYLE SLIDER BED BELT CONVEYOR W/ ROUND END PLATES

24 HOUR SHIPMENTS INCLUDE ALL 1-FOOT INCREMENTS 5'-0" TO 100'-0"



Conveyor shown with optional supports

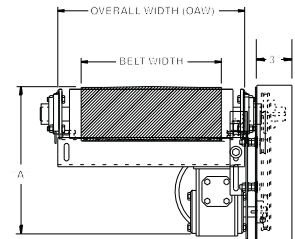

Model 450BOS slider bed belt conveyor is one of the most popular and common means of transporting goods for packing, testing, inspecting and a variety of assembly line operations. 450BOS features a box style slider bed, ideal for workers stationed alongside the conveyor.

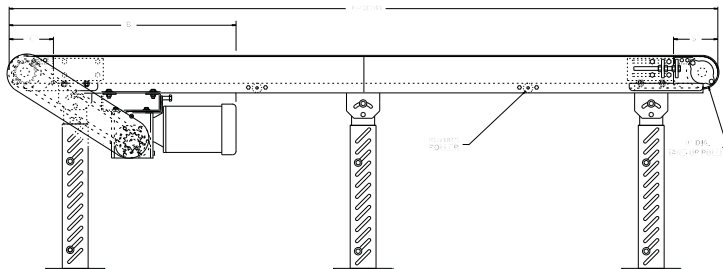

HP@ 60 FPM	"A" MAX		"B" MAX	
	4" DRV.	8" DRV.	4" DRV.	8" DRV.
1/3	13-13/16"	13-13/16"	29-3/32"	32-3/32"
1/2	13-13/16"	13-13/16"	29-3/32"	32-3/32"
3/4	14-3/16"	14-3/16"	29-23/32"	32-23/32"
1	14-1/2"	14-1/2"	30-15/32"	33-15/32"
1-1/2	15-9/16"	15-9/16"	32-19/32"	35-19/32"
2	16-7/16"	16-7/16"	33-19/32"	36-19/32"

SPECIFICATIONS

BELTING: PVC-120 black.

DRIVE PULLEY: 4" dia. with 1-3/16" dia. shaft or 8" dia. with 1-7/16" dia. shaft, both machine crowned and fully lagged, mounted in round style end plates.

TAIL PULLEY: 4" dia., machine crowned, with 1-3/16" dia. shaft, mounted in round style end plates.

END DRIVE: Allows one-direction (unit) operation; add optional center drive for reversible application.

TAKE-UP: Belt take-up provided at tail pulley with screw type unit.

BELT SPEED: 60 FPM, constant.

BED: 4-1/2" deep x 12 ga. box type construction with bed pan braces (30" OAW and above) and round style end plates.

BEARINGS: All pulley bearings are precision, heavy duty, lubricated, ball bearing units with cast iron housings.

RETURN ROLLERS: 1.9" dia. x 16 ga. steel, model 196S, adjustable.

MOTOR DRIVE: 1/3 HP, 230/460/3, 60 cycle, ODP right angle gear motor.

ROLLER CHAIN: Drive pulley is driven by No. 50 roller chain for 1-1/2 HP or less and No. 60 chain on larger drives. Chain take-up provided on motor base.

ELECTRICAL CONTROLS: Optional.

SPECIFICATIONS

CONSTRUCTION: Brackets are 10 ga. HRS painted steel and bolt at end of powered conveyor to butt couplings. Gravity conveyor attaches to connector bracket.

POP-OUT ROLLERS: Mounts into slot on bracket for safety design. Use of connector bracket eliminates dangerous pinch points.

CBOS-4-24

CBOS-(pulley diameter*)-(overall width)

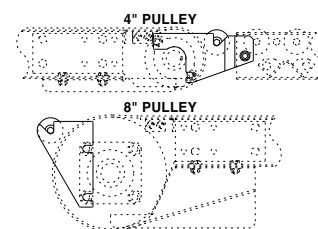

WARNING

Prevent pinch points that exist when belt conveyors are permanently attached to other conveyors or equipment! Use connector brackets with safety pop out rollers shown above.



SPECIFICATION TABLE

50'-0" lengths and under are equipped with 4" dia. drive pulley; over 50'-0" includes 8" dia. drive pulley

■ 24 hour shipment ■ 2 week shipment

CONVEYOR LENGTH		10'	20'	30'	40'	50'	60'	70'	80'	90'	100'	DEDUCT
BELT	BED	UNIT WEIGHTS (lbs.)										PER FOOT
6"	9"	203	295	387	479	571	663	755	847	939	1031	9
12"	15"	263	395	528	660	793	925	1058	1190	1323	1455	13
18"	21"	323	496	669	842	1015	1188	1361	1534	1706	1879	17
24"	27"	383	596	810	1023	1237	1450	1663	1877	2090	2304	21
30"	33"	443	697	951	1205	1458	1712	1966	2220	2474	2728	25
36"	39"	503	797	1092	1386	1680	1975	2269	2563	2858	3152	29

OPTIONAL EQUIPMENT

BELTING: Black PVC ruff-top; 3-ply brown neoprene ruff-top; PVC-120 white food grade COS; PVC-150 black COS; 3-ply CN 40 urethane cover. Consult factory for other belting.

CENTER DRIVE: Reversible drive with integral belt take-up of 24". Specify location. Center drive option available on units 6'-0" long and above.

SIDE MOUNTED END DRIVE: Provides minimum conveyor height of 10" TOB (4" dia. drive pulley); 11" TOB (8" dia. drive pulley).

OVERHEAD END DRIVE: Provides minimum conveyor height of 6" TOB (4" dia. drive pulley); 10" TOB (8" dia. drive pulley).

AUXILIARY TAKE-UP: Provides 24" of belt take-up. Specify location. See Power Accessories.

SIDE TABLES: Available in 9", 15" and 21" widths (14 ga.) one or both sides. See Power Accessories.

FLOOR SUPPORTS: Supports, knee braces, casters and polytier supports available. See Conveyor Accessories.

NOSE-OVER: Provides smooth transition from incline to horizontal position. Single nose-over adjusts 0-20°; double nose-over adjusts 0-35°. See Power Accessories.

UNDERTRUSSED BED: Available to provide clearance underneath unit at bed joint locations. Specify location for undertrussing and desired clearance underneath unit. Consult factory.

CEILING HANGERS: 5/8" dia. threaded rod with hardware to attach rods to conveyor. Provides 6' clearance between ceiling and TOB (furnished in place of floor supports). See Conveyor Accessories.

MOTORS: Available through 3 HP in TEFC, explosion proof, dirty duty, brake motor, 115/230/1, 575/3, etc.

GUARD RAILS: 1-3/4" x 1" formed channel (model GC), adjusts horizontally to 10" wider than belt and vertically to 6" above belt; formed steel fixed (model FSG in 2", 4", 6", 8", 12", and 18" heights; fixed channel (model FC); 1-1/2" angle (model GA1-1/2). See Conveyor Accessories.

BELT SPEED: Constant speed 10-120 FPM; DC variable speed; AC inverter variable speed. Other constant or variable speeds available.

NOTE: CAPACITY CHANGES WITH SPEED.

ELECTRICAL CONTROLS: Magnetic starter (one direction or reversible); One direction manual starter; Momentary start/stop push button station; Forward/reversing /stop push button station. Mounting and pre-wiring for units up to 12' long.



4" END DRIVE WITH ROUND END PLATES



MODEL 796RB MEDIUM DUTY ROLLER BED BELT CONVEYOR

24 HOUR SHIPMENTS INCLUDE ALL 1-FOOT INCREMENTS 5'-0" TO 100'-0"



Conveyor shown with optional supports

Model 796RB, medium duty roller bed belt conveyor, is well suited for transporting unit loads with lesser horsepower requirements than slider bed belt conveyors.

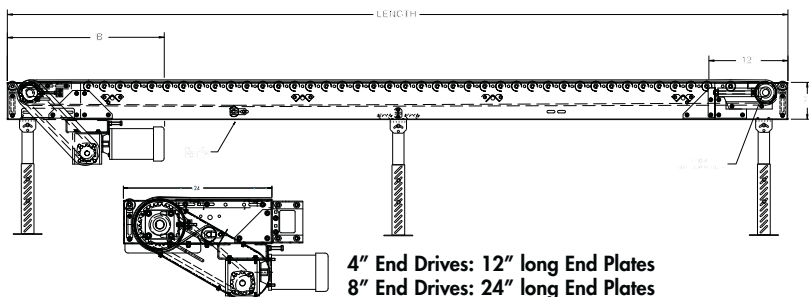
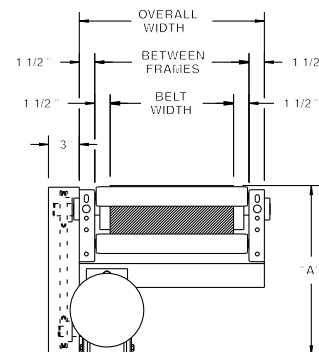

4" End Drives: 12" long End Plates
8" End Drives: 24" long End Plates

HP @ 60 FPM	"A" MAX		"B" MAX	
	4" DRV.	8" DRV.	4" DRV.	8" DRV.
1/3	16-5/8"	16-5/8"	27-3/32"	33-3/32"
1/2	16-5/8"	16-5/8"	27-3/32"	33-3/32"
3/4	17"	17"	27-23/32"	33-23/32"
1	17-1/4"	17-1/4"	28-15/32"	34-15/32"
1-1/2	18-1/8"	18-1/8"	31-3/32"	37-3/32"
2	19"	19"	32-3/32"	38-3/32"

SPECIFICATIONS

BELTING: PVC-120 black.

CARRIER ROLLERS: 1.9" dia. x 16 ga. steel rollers, model 196S.

DRIVE PULLEY: 4" dia. with 1-3/16" dia. shaft or 8" dia. with 1-7/16" dia. shaft, both machine crowned and fully lagged.

TAIL PULLEY: 4" dia., machine crowned, with 1-3/16" dia. shaft.

END DRIVE: Allows one-direction (unit) operation; add optional center drive for reversible application.

SAFETY POP-OUT ROLLER: Standard on both ends, 1.9" dia. x 16 ga. steel roller, model 196S.

SQUARING RODS: Adjustable rods on underside of bed allow frame to be squared for improved belt tracking and are standard on all units over 30'.

BED: 7" x 1-1/2" x 12 ga. channel frame. Bed sections attached with couplings and floor supports.

BEARINGS: All pulley bearings are precision, heavy duty, lubricated, ball bearing units with cast iron housings.

TAKE-UP: Screw type unit at tail pulley provides 12" belt take-up.

BELT SPEED: 60 FPM, constant.

RETURN ROLLERS: 1.9" dia. x 16 ga. steel, model 196S, adjustable.

ROLLER CHAIN: Drive pulley is driven by No. 50 roller chain for 1-1/2 HP or less and No. 60 chain on larger drives. Chain take-up provided on motor base.

MOTOR DRIVE: 1/3 HP, 230/460/3, 60 cycle, ODP right angle gear motor.

ELECTRICAL CONTROLS: Optional.

⚠️ WARNING

Prevent pinch points that exist when belt conveyors are permanently attached to other conveyors or equipment!



SPECIFICATION TABLE

50'-0" lengths and under are equipped with 4" dia. drive pulley; over 50'-0" includes 8" dia. drive pulley

■ 24 hour shipment ■ 2 week shipment

CONVEYOR LENGTH			10'	20'	30'	40'	50'	60'	70'	80'	90'	100'	Deduct
BELT	BF	OAW	UNIT WEIGHTS (lbs.) with 3" Roller Center (For other centers, deduct weights below)										Per Foot
12"	15"	18"	346	564	781	999	1217	1434	1652	1870	2087	2305	22
18"	21"	24"	413	683	953	1223	1493	1764	2034	2304	2574	2845	27
24"	27"	30"	479	802	1125	1447	1770	2093	2416	2739	3062	3384	32
30"	33"	36"	546	921	1296	1672	2047	2422	2798	3173	3549	3924	38
36"	39"	42"	612	1040	1468	1896	2324	2752	3180	3608	4036	4464	43
42"	45"	48"	679	1159	1640	2120	2601	3081	3562	4042	4523	5003	48
48"	51"	54"	745	1278	1811	2344	2877	3411	3944	4477	5010	5543	53

Deduct the following weights (lbs.) for other than 3" centers

Roller Centers	12" BELT		18" BELT		24" BELT		30" BELT		36" BELT		42" BELT		48" BELT	
	Per 5'	Per 10'	Per 5'	Per 10'	Per 5'	Per 10'	Per 5'	Per 10'	Per 5'	Per 10'	Per 5'	Per 10'	Per 5'	Per 10'
4-1/2"	-15	-30	-20	-40	-25	-50	-30	-60	-35	-70	-40	-80	-45	-90
6"	-30	-60	-40	-80	-50	-100	-60	-120	-70	-140	-80	-160	-90	-180
9"	-42	-78	-56	-104	-70	-130	-84	-156	-98	-182	-112	-208	-99	-234
12"	-45	-90	-60	-120	-75	-150	-90	-180	-105	-210	-120	-240	-135	-270

OPTIONAL EQUIPMENT

BELTING: Black PVC ruff-top; 3-ply brown neoprene ruff-top; PVC-120 white food grade COS; PVC-150 black COS; 3-ply CN 40 urethane cover. Consult factory for other belting.

CENTER DRIVE: Reversible drive with integral belt take-up of 24". Specify location. Center drive option available 6'-0" long units & above.

SIDE MOUNTED END DRIVE: Provides minimum conveyor height of 10" TOB (4" dia. drive pulley); 12" TOB (8" dia. drive pulley).

OVERHEAD END DRIVE: Provides minimum conveyor height of 8" TOB (4" dia. drive pulley); 10" TOB (8" dia. drive pulley).

AUXILIARY TAKE-UP: Provides 24" of belt take-up. Specify location. See Power Accessories.

SIDE TABLES: Available in 9", 15" and 21" widths (14 ga.) one or both sides. See Power Accessories.

FLOOR SUPPORTS: Supports, knee braces, casters and polytier supports available. See Conveyor Accessories.

CEILING HANGERS: 5/8" dia. threaded rod with hardware to attach rods to conveyor. Provides 6' clearance between ceiling and TOB (furnished in place of floor supports). See Conveyor Accessories.

UNDERTRUSSED BED: Available to provide clearance underneath unit at bed joint locations. Specify location for undertrussing and desired clearance underneath unit. Consult factory.

BELT SPEED: Constant speed 10-120 FPM; DC variable speed; AC inverter variable speed. Other constant or variable speeds available. **NOTE: CAPACITY CHANGES WITH SPEED.**

MOTORS: Available through 3 HP in TEFC, explosion proof, dirty duty, brake motor, 115/230/1, 575/3, etc.

NOSE-OVER: Provides smooth transition from incline to horizontal position. Single nose-over adjusts 0-20°; double nose-over adjusts 0-35°. See Power Accessories.

GUARD RAILS: 1-3/4" x 1" formed channel (model GC), adjusts horizontally to 10" wider than belt and vertically to 6" above belt; formed steel fixed (model FSG in 2", 4", 6", 8", 12", and 18" heights; fixed channel (model FC); 1-1/2" angle (model GA1-1/2). See Conveyor Accessories.

ELECTRICAL CONTROLS: Magnetic starter (one direction or reversible); One direction manual starter; Momentary start/stop push button station; Forward/reversing /stop push button station. Mounting and pre-wiring for units up to 12' long.

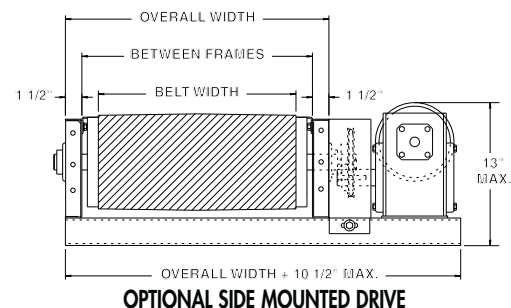

MODEL 796RBF ROLLER BED INCLINED FLOOR-TO-FLOOR BELT CONVEYOR

24 HOUR SHIPMENTS INCLUDE ALL 1-FOOT INCREMENTS 10'-0" TO 50'-0"



Model 796RBF floor-to-floor conveyor provides higher load capacity, reversible flow and nose-over allows for simple adjustments for inclines 0-35°. Shown with optional supports, knee braces, chain driven feeder and right hand drive. All units furnished standard with left hand drive.

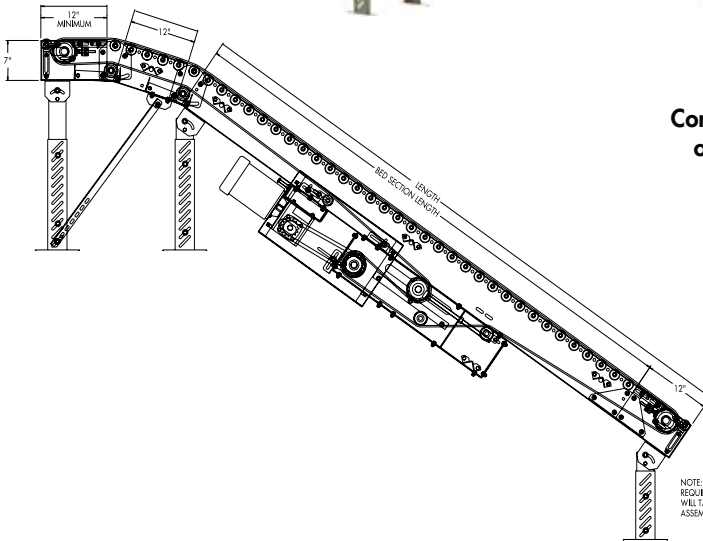

Conveyor shown with optional supports

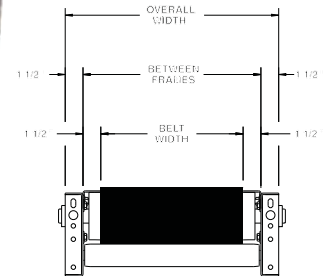

HP @ 60 FPM	"A" MAX		"B" MAX	
	4" DRV.	8" DRV.	4" DRV.	8" DRV.
1/3	16-5/8"	17-5/8"	58-5/32"	58-5/32"
1/2	16-5/8"	17-5/8"	58-5/32"	58-5/32"
3/4	17"	17-5/8"	58-25/32"	58-25/32"
1	17-1/4"	17-5/8"	59-17/32"	59-17/32"
1-1/2	18-1/8"	18-1/8"	61-21/32"	61-21/32"
2	19"	19"	62-21/32"	62-21/32"

NOTE: WHEN CHAIN FEEDER IS REQUIRED END DRIVE ASSEMBLY WILL TAKE PLACE OF BED END ASSEMBLY FOR CONNECTION.

SPECIFICATIONS

BELTING: Black PVC ruff-top.

CARRIER ROLLERS: 1.9" dia. X 16 ga. steel, model 196S.

DRIVE PULLEY: 8" dia. with 1-7/16" dia. shaft, both machine crowned and fully lagged.

TAIL PULLEY: 4" dia., machine crowned, with 1-3/16" dia. shaft.

RETURN ROLLERS: 1.9" dia. x 16 ga. steel, model 196S, adjustable.

CENTER DRIVE: Reversible drive with 24" integral belt take-up.

SAFETY POP-OUT ROLLER: Standard on both ends, 1.9" dia. x 16 ga. steel roller, model 196S.

BELT SPEED: 60 FPM, constant.

BED: 7" x 1-1/2" x 12 ga. channel frame. Bed sections attached with couplings and floor supports.

NOSE-OVER: Provides smooth transition from incline to horizontal position. Single nose-over adjusts 0-20°; double nose-over adjusts 0-35° (specify single or double).

BEARINGS: All pulley bearings are precision, heavy duty, lubricated, ball bearing units with cast iron housings.

MOTOR DRIVE: 1/3 HP, 230/460/3, 60 cycle, ODP right angle gear motor.

ROLLER CHAIN: Drive pulley is driven by No. 50 roller chain for 1-1/2 HP or less and No. 60 chain on larger drives. Chain take-up provided on motor base.

FLOOR SUPPORTS: Optional.

ELECTRICAL CONTROLS: Optional.

⚠ WARNING

Prevent pinch points that exist when belt conveyors are permanently attached to other conveyors or equipment!



SPECIFICATION TABLE

■ 24 hour shipment ■ 2 week shipment

CONVEYOR LENGTH			10'	20'	30'	40'	50'	Deduct
BELT	BF	OAW	Unit weights (lbs.) with 6" roller centers (For other centers, deduct weights below)					Per Foot
12"	15"	18"	730	930	1130	1331	1531	22
18"	21"	24"	857	1111	1364	1618	1872	27
24"	27"	30"	983	1291	1598	1906	2213	32
30"	33"	36"	1110	1471	1832	2194	2555	38
36"	39"	42"	1237	1652	2066	2481	2896	43
42"	45"	48"	1363	1832	2300	2769	3238	48
48"	51"	54"	1234	1776	2319	2861	3403	54

Deduct the following weights (lbs.) for other than 6" centers

Roller Centers	12" BELT		18" BELT		24" BELT		30" BELT		36" BELT		42" BELT		48" BELT	
	Per 5'	Per 10'	Per 5'	Per 10'	Per 5'	Per 10'	Per 5'	Per 10'	Per 5'	Per 10'	Per 5'	Per 10'	Per 5'	Per 10'
9"	-9	-18	-12	-24	-15	-30	-18	-36	-21	-42	-24	-48	-27	-54
12"	-15	-30	-20	-40	-25	-50	-30	-60	-35	-75	-40	-80	-45	-90

OPTIONAL EQUIPMENT

BELTING: 3 ply, brown neoprene ruff-top. Consult factory for other belting.

SIDE MOUNTED END DRIVE: Available as option when necessary to move center drive for unit clearance. Minimum horizontal nose-over length required is 3' (2' horizontal may be used if product does not overhang conveyor OAW).

192S CARRIER ROLLERS: 1.9" dia. x 12 ga. steel carrier rollers, model 192S, available in model 192RBF.

UNDERTRUSSED BED: Available to provide clearance underneath unit at bed joint locations. Specify location for undertrussing and desired clearance underneath unit. Consult factory.

FLOOR SUPPORTS: Various height adjustable supports and knee braces available. See Conveyor Accessories.

POWERED FEEDER: Integral belt feeder or separate chain driven belt feeder.

CEILING HANGERS: 5/8" dia. threaded rod w/ hardware to attach rods (specify rod length) to conveyor. See Conveyor Accessories.

GUARD RAILS: 1-3/4" x 1" formed channel (model GC), adjusts horizontally to 10" wider than belt and vertically to 6" above belt; formed steel fixed (model FSG in 2", 4", 6", 8", 12", and 18" heights. See Conveyor Accessories.

BELT SPEED: Constant speed 3-120 FPM; DC variable speed; AC inverter variable speed. Other constant or variable speeds available.
NOTE: CAPACITY CHANGES WITH SPEED.

MOTORS: Available through 3 HP in TEFC, explosion proof, dirty duty, brake motor, 115/230/1, 575/3, etc.

ELECTRICAL CONTROLS: Magnetic starter (one direction or reversible); One direction manual starter; Momentary start/stop push button station; For-ward/reversing/stop push button station.

Chain Feeder

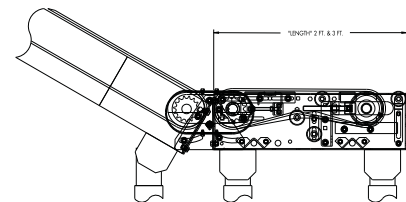

Integral Feeder

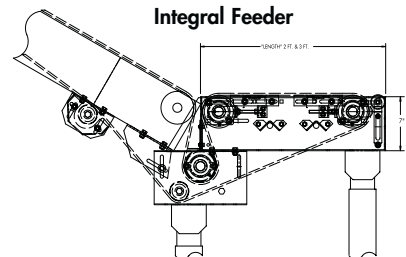

OPTIONAL CHAIN DRIVEN FEEDER



OPTIONAL INTEGRAL FEEDER



MODEL 700SBF SLIDER BED INCLINED FLOOR-TO-FLOOR BELT CONVEYOR

24 HOUR SHIPMENTS INCLUDE ALL 1-FOOT INCREMENTS 10'-0" TO 50'-0"

Model 700SBF floor-to-floor conveyor provides higher load capacity, reversible flow and nose-over allows for simple adjustments for inclines 0-35°. Shown with optional supports, knee braces, chain driven feeder and right hand drive. All units furnished standard with left hand drive.

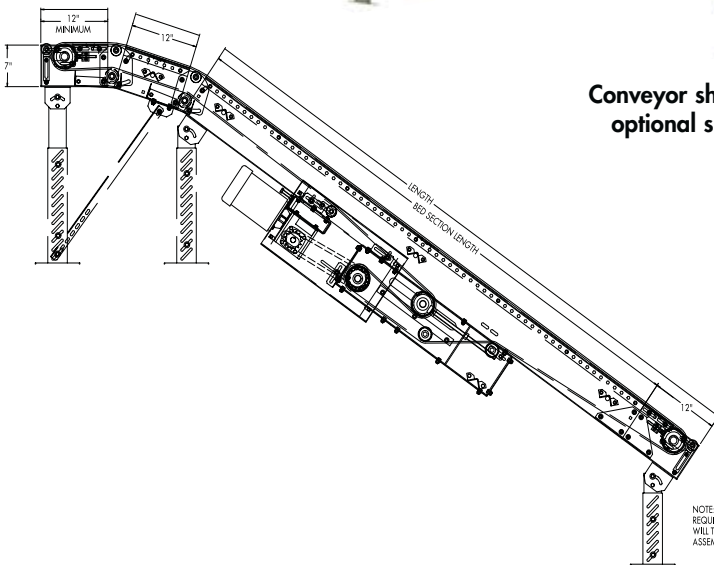
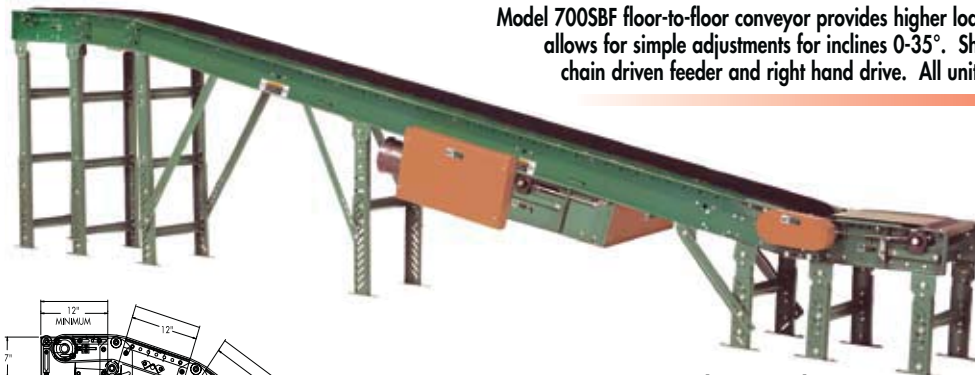

Conveyor shown with optional supports

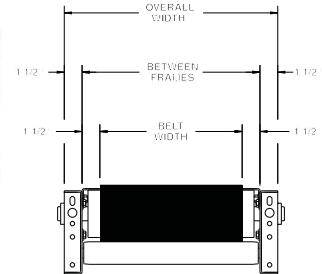

HP@ 60 FPM	"A" MAX		"B" MAX	
	4" DRV.	8" DRV.	4" DRV.	8" DRV.
1/3	16-5/8"	17-5/8"	58-5/32"	58-5/32"
1/2	16-5/8"	17-5/8"	58-5/32"	58-5/32"
3/4	17"	17-5/8"	58-25/32"	58-25/32"
1	17-1/4"	17-5/8"	59-17/32"	59-17/32"
1-1/2	18-1/8"	18-1/8"	61-21/32"	61-21/32"
2	19"	19"	62-21/32"	62-21/32"

NOTE: WHEN CHAIN FEEDER IS REQUIRED END DRIVE ASSEMBLY WILL TAKE PLACE OF FIXED END ASSEMBLY FOR CONNECTION.

SPECIFICATIONS

BELTING: Black PVC ruff-top.

DRIVE PULLEY: 8" dia. with 1-7/16" dia. shaft, both machine crowned and fully lagged.

TAIL PULLEY: 4" dia., machine crowned, with 1-3/16" dia. shaft.

RETURN ROLLERS: 1.9" dia. x 16 ga. steel, model 196S, adjustable.

CENTER DRIVE: Reversible drive with 24" integral belt take-up.

BELT SPEED: 60 FPM, constant.

SAFETY POP-OUT ROLLER: Standard on both ends, 1.9" dia. x 16 ga. steel roller, model 196S.

NOSE-OVER: Provides smooth transition from incline to horizontal position. Single nose-over adjusts 0-20°; double nose-over adjusts 0-35° (specify single or double).

BEARINGS: All pulley bearings are precision, heavy duty, lubricated, ball bearing units with cast iron housings.

BED: 7" x 1-1/2" x 12 ga. channel frame with 14 ga. slider bed 9"-39" BF; 12 ga. slider bed 45" & 51" BF.

ROLLER CHAIN: Drive pulley is driven by No. 50 roller chain for 1-1/2 HP or less and No. 60 chain on larger drives. Chain take-up provided on motor base.

MOTOR DRIVE: 1/3 HP, 230/460/3, 60 cycle, ODP right angle gear motor.

FLOOR SUPPORTS: Optional.

ELECTRICAL CONTROLS: Optional.

⚠ WARNING

Prevent pinch points that exist when belt conveyors are permanently attached to other conveyors or equipment!



SPECIFICATION TABLE

■ 24 hour shipment ■ 2 week shipment

CONVEYOR LENGTH			10'	20'	30'	40'	50'	Deduct
BELT	BF	OAW	Units weights (lbs.)					Per Foot
6"	9"	12"	392	506	621	735	849	11
12"	15"	18"	501	657	813	969	1125	16
18"	21"	24"	610	808	1006	1204	1402	20
24"	27"	30"	719	959	1199	1438	1678	24
30"	33"	36"	828	1110	1391	1673	1955	28
36"	39"	42'	937	1261	1584	1908	2231	32

OPTIONAL EQUIPMENT

BELTING: 3 ply, brown neoprene ruff-top. Consult factory for other belting.

SIDE MOUNTED END DRIVE: Available as option when necessary to move center drive for unit clearance. Minimum horizontal nose-over length required is 3' (2' horizontal may be used if product does not overhang conveyor OAW).

BED: Available in boxed slider bed.

UNDERTRUSSED BED: Available to provide clearance underneath unit at bed joint locations. Specify location for undertrussing and desired clearance underneath unit. Consult factory.

FLOOR SUPPORTS: Various height adjustable supports and knee braces available. See Conveyor Accessories.

POWERED FEEDER: Integral belt feeder or separate chain driven belt feeder.

MOTORS: Available through 3 HP in TEFC, explosion proof, dirty duty, brake motor, 115/230/1, 575/3, etc.

CEILING HANGERS: 5/8" dia. threaded rod w/ hardware to attach rods (specify rod length) to conveyor. See Conveyor Accessories.

GUARD RAILS: 1-3/4" x 1" formed channel (model GC), adjusts horizontally to 10" wider than belt and vertically to 6" above belt; formed steel fixed (model FSG in 2", 4", 6", 8", 12", and 18" heights. See Conveyor Accessories.

BELT SPEED: Constant speed 3-120 FPM; DC variable speed; AC inverter variable speed. Other constant or variable speeds available. **NOTE: CAPACITY CHANGES WITH SPEED.**

ELECTRICAL CONTROLS: Magnetic starter (one direction or reversible); One direction manual starter; Momentary start/stop push button station; Forward/reversing/stop push button station.

Chain Feeder

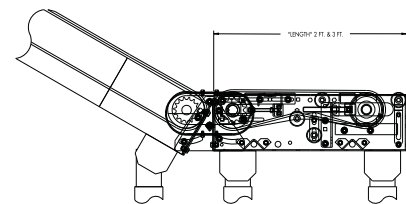

Integral Feeder

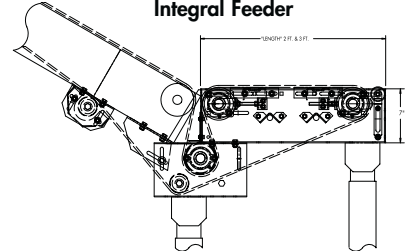

OPTIONAL CHAIN DRIVEN FEEDER



OPTIONAL INTEGRAL FEEDER



MODEL 751RB HEAVY DUTY ROLLER BED BELT CONVEYOR

24 HOUR SHIPMENTS INCLUDE ALL 1-FOOT INCREMENTS 5'-0" TO 100'-0"



Conveyor shown with optional supports

Roach 751RB is the choice for heavier unit loads. The heavy duty roller bed construction makes model 751RB ideal for transporting heavy loads with low power requirements.

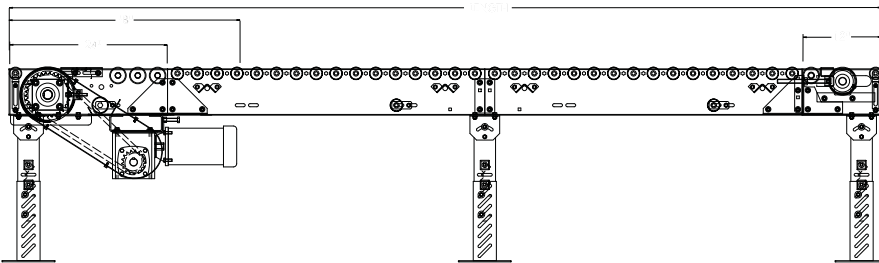
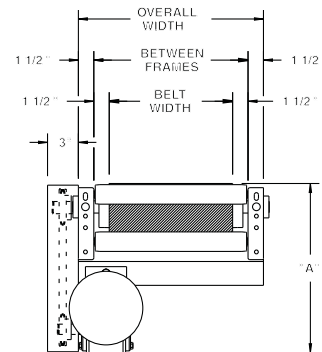

HP@ 60 FPM	"A" MAX 8" DRV.	"B" MAX 8" DRV.
1	17-1/4"	34-15/32"
1-1/2"	18-1/8"	37-3/32"
2	19"	38-3/32"
3	19-1/2"	39-9/32"

SPECIFICATIONS

BELTING: PVC-120 black.

CARRIER ROLLERS: 2-1/2" dia. x 11 ga. steel, model 251S.

DRIVE PULLEY: 8" dia. with 1-7/16" dia. shaft on 15"-39" BF; 12" dia. with 1-15/16" dia. shaft above 39" BF; both machine crowned and fully lagged.

TAIL PULLEY: 4" dia. with 1-3/16" dia. shaft on 15"-39" BF; 6" dia. with 1-7/16" dia. shaft above 39" BF; both machine crowned.

RETURN ROLLERS: 1.9" dia. x 16 ga. steel, model 196S, adjustable.

BELT SPEED: 35 FPM, constant.

END DRIVE: Allows one-direction (unit) operation; add optional center drive for reversible application.

TAKE-UP: Screw type unit at tail pulley provides 12" belt take-up.

BEARINGS: All pulley bearings are precision, heavy duty, lubricated, ball bearing units with cast iron housings.

BED: 7" x 1-1/2" x 10 ga. channel frame. Bed sections attach with couplings and floor supports.

SAFETY POP-OUT ROLLERS: Standard on both ends, 1.9" x 12 ga. steel, model 192S on 15"-39" BF, 1.9" x 9 ga. steel, model 199S on 45"-57" BF.

SQUARING RODS: Adjustable rods on underside of bed allow frame to be squared for improved belt tracking and are standard on all units over 30'.

ROLLER CHAIN: Drive pulley is driven by No. 50 roller chain for 1-1/2 HP or less and No. 60 chain on larger drives. Chain take-up provided on motor base.

MOTOR DRIVE: 1 HP, 230/460/3, 60 cycle, ODP right angle gear motor.

ELECTRICAL CONTROLS: Optional.

⚠️ WARNING

Prevent pinch points that exist when belt conveyors are permanently attached to other conveyors or equipment!



SPECIFICATION TABLE

■ 24 hour shipment ■ 3 week shipment

CONVEYOR LENGTH			10'	20'	30'	40'	50'	60'	70'	80'	90'	100'	Deduct
BELT	BF	OAW	UNIT WEIGHTS (lbs.) with 6" Roller Centers (For other centers, deduct weights below)										Per Foot
15"	18"	12"	499	892	1285	1677	2070	2463	2856	3248	3641	4034	39
21"	24"	18"	619	1104	1588	2073	2557	3042	3526	4011	4495	4980	49
27"	30"	24"	739	1315	1892	2468	3044	3620	4197	4773	5349	5925	57
33"	36"	30"	859	1527	2193	2863	3531	4199	4867	5535	6203	6871	67
39"	42"	36"	979	1739	2499	3258	4018	4778	5538	6297	7057	7817	76
45"	48"	42"	1099	1951	2802	3654	4505	5357	6208	7060	7911	8763	85
51"	54"	48"	1219	2162	3106	4049	4992	5935	6879	7822	8765	9708	94
57"	60"	54"	1339	2374	3409	4444	5479	6514	7549	8584	9619	10654	104

Deduct the following weights (lbs.) for other than 3" centers

Roller Centers	15" BF	21" BF	27" BF	33" BF	39" BF	45" BF	51" BF	57" BF
	Per 10'	Per 10'	Per 10'	Per 10'	Per 10'	Per 10'	Per 10'	Per 10'
4-1/2"	-72	-90	-112	-136	-158	-178	-200	-220
6"	-144	-180	-224	-272	-316	-356	-400	-440
9"	-186	-234	-300	-354	-410	-464	-518	-572
12"	-216	-270	-336	-408	-474	-534	-600	-660

OPTIONAL EQUIPMENT

BELTING: Black PVC ruff-top; 3-ply brown neoprene ruff-top; PVC-120 white food grade COS; PVC-150 black COS; 3-ply CN 40 urethane cover. Consult factory for other belting.

CENTER DRIVE: Reversible drive with integral belt take-up of 24". Specify location. Center drive option available on units 6'-0" long and above.

SIDE MOUNTED END DRIVE: Provides minimum conveyor height of 12" TOB (8" dia. drive pulley); 16" TOB (12" dia. drive pulley).

OVERHEAD END DRIVE: Provides minimum conveyor height of 12" TOB (8" dia. drive pulley); 16" TOB (12" dia. drive pulley).

AUXILIARY TAKE-UP: Provides 24" of belt take-up. Specify location. See Power Accessories.

FLOOR SUPPORTS: Supports, knee braces, casters and polytier supports available. See Conveyor Accessories.

GUARD RAILS: HFSG in 2", 4" and 6" heights; 1-1/2" angle (model HGA1-1/2). See Conveyor Accessories.

NOSE-OVER: Provides smooth transition from incline to horizontal position. Consult factory.

SIDE TABLES: Available in 9", 15" and 21" widths. Consult factory.

BELT SPEED: Constant speed 12-120 FPM; DC variable speed; AC inverter variable speed. Other constant or variable speeds available.

NOTE: CAPACITY CHANGES WITH SPEED.

CEILING HANGERS: Heavy duty with hardware to attach rods to conveyor. Consult factory.

MOTORS: Available through 3 HP in TEFC, explosion proof, dirty duty, brake motor, 115/230/1, 575/3, etc.

ELECTRICAL CONTROLS: Magnetic starter (one direction or reversible); One direction manual starter; Momentary start/stop push button station; Forward/reversing /stop push button station. Mounting and pre-wiring for units up to 12' long.

