



Machining & Welding
www.MachiningAndWelding.com

Sales@MachiningAndWelding.com

Material Handling Pallet Lifters

Pallet Lifters

- Manufactured to exceed all ASME B30.20 and OSHA regulations.
- Painted safety yellow for increased visibility.
- **ALL** material handling equipment proof loaded and shipped with certification paperwork.
- Durable construction ideally suited to jobsite or warehouse use.
- Made in U.S.A.
- Machined to exacting tolerances.
- Custom lettering available - call for details.
- Custom designs available - call for engineering.
- **ALL** lifting equipment individually proof loaded per OSHA requirements.

RFID TRACKING



CHIP EQUIPPED



- Converts crane or hoist into aerial forklift.
- Rear guide for operator safety.
- Fork Length : 36"
- Fork Spacing : 25"
- Dual Lift Bale adjustment

Working Load Limit in Pounds*	Part Number	Weight in Pounds
2,000	14511	190
4,000	14512	335
6,000	14513	460
8,000	16664	660

* Call for specifications on larger sizes and capacities



Machining & Welding
www.MachiningAndWelding.com

Sales@MachiningAndWelding.com

Material Handling Pallet Lifters

Pallet Lifters

- Manufactured to exceed all ASME B30.20 and OSHA regulations.
- Painted safety yellow for increased visibility.
- **ALL** material handling equipment proof loaded and shipped with certification paperwork.
- Durable construction ideally suited to jobsite or warehouse use.
- Made in U.S.A.
- Machined to exacting tolerances.
- Custom lettering available - call for details.
- Custom designs available - call for engineering.
- **ALL** lifting equipment individually proof loaded per OSHA requirements.

Working Load Limit in Pounds*	Part Number	Weight in Pounds	HR	L	W	D	G
2,000	14631	190	57	48	25	24	48
4,000	14630	760	59	48	25	24	48
6,000	14629	965	62	48	27	24	48

* Call for specifications on larger sizes and capacities

RFID TRACKING



CHIP EQUIPPED

- Converts crane or hoist into aerial forklift.
- Heavy duty frame design.
- Counter balance allows lifter to hang level when empty.

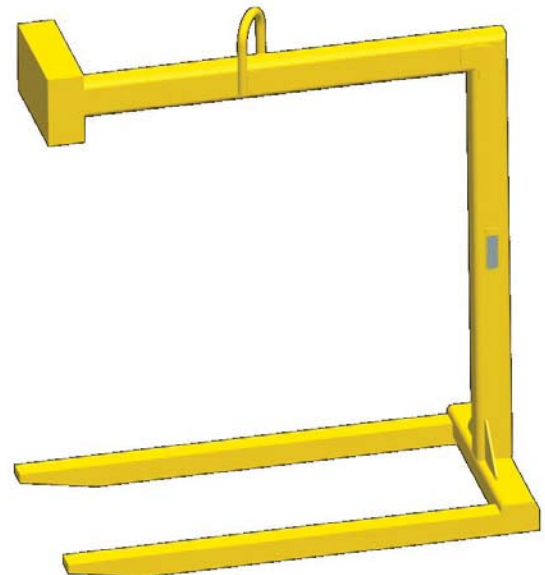
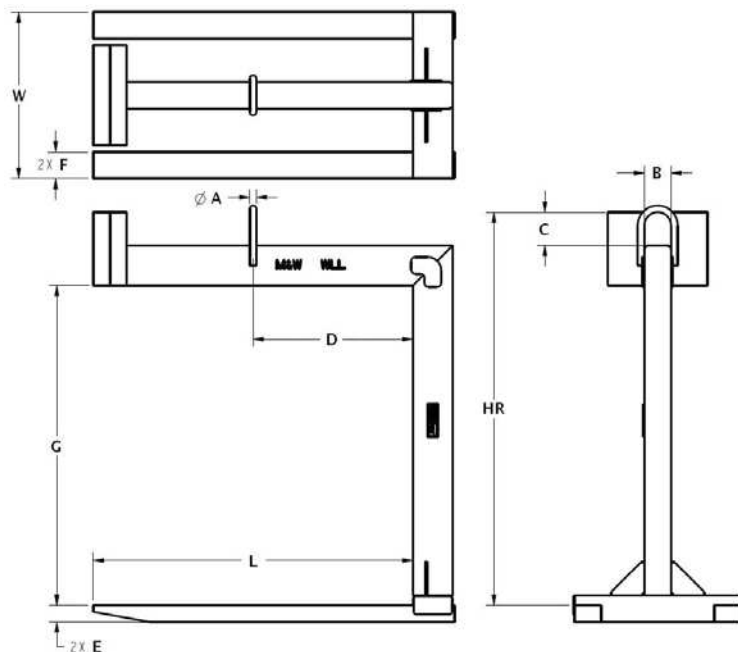

MATERIAL HANDLING

**Material Handling
Pallet Lifter with Adjustable Lifting Base and Adjustable
Lift Bale**

Machining & Welding
www.MachiningAndWelding.com

Sales@MachiningAndWelding.com



Pallet Lifter with Adjustable Lifting Base and Adjustable Lift Bale

- Manufactured to exceed all ASME B30.20 and OSHA regulations.
- Painted safety yellow for increased visibility.
- **ALL** material handling equipment proof loaded and shipped with certification paperwork.
- Durable construction ideally suited to jobsite or warehouse use.
- Made in U.S.A.
- Machined to exacting tolerances.
- Custom lettering available - call for details.
- Custom designs available - call for engineering.
- **ALL** lifting equipment individually proof loaded per OSHA requirements.
- Converts crane or hoist into aerial forklift.
- Rear guide for operator safety.
- Fork Length : 42"
- Adjustable Fork Spacing : 17 - 36"

Working Load Limit in Pounds*	Part Number	A	B	C	D	Weight in Pounds
4,000	12412	42	17 to 36	2	4	400

* Call for specifications on larger sizes and capacities

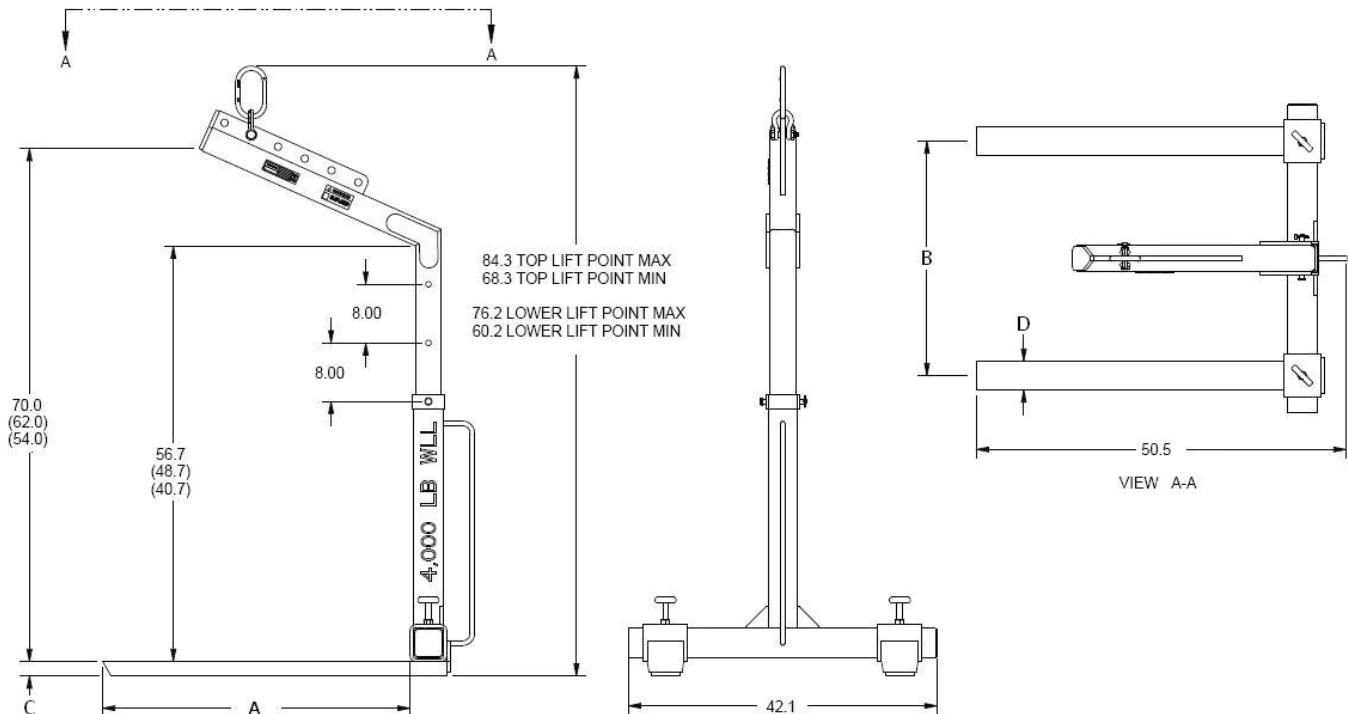
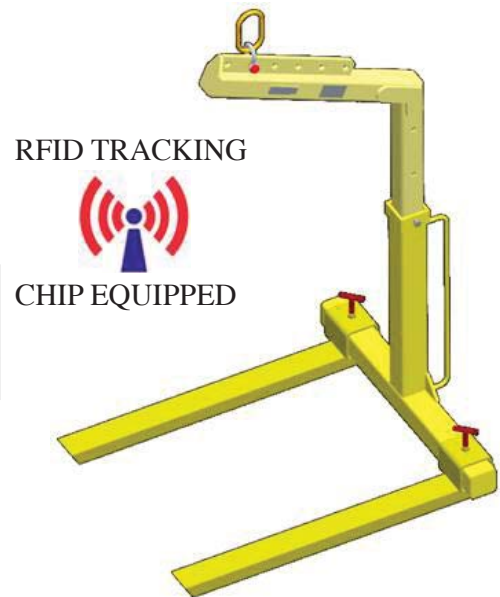

MATERIAL HANDLING

**Material Handling
Wheeled Pallet Lifters**

Machining & Welding
www.MachiningAndWelding.com

Sales@MachiningAndWelding.com



Wheeled Pallet Lifters

- Manufactured to exceed all ASME B30.20 and OSHA regulations.
- Painted safety yellow for increased visibility.
- **ALL** material handling equipment proof loaded and shipped with certification paperwork.
- Durable construction ideally suited to jobsite or warehouse use.
 - Converts crane or hoist into aerial forklift.
 - Rear guide for operator safety.
 - Fork Length : 36"
 - Fork Spacing : 25"
 - Multiple Lift Bale adjustments.
- Made in U.S.A.
- Machined to exacting tolerances.
- Custom lettering available - call for details.
- Custom designs available - call for engineering.
- **ALL** lifting equipment individually proof loaded per OSHA requirements.

Working Load Limit in Pounds*	Part Number	Weight in Pounds
4,000	14998	330

* Call for specifications on larger sizes and capacities

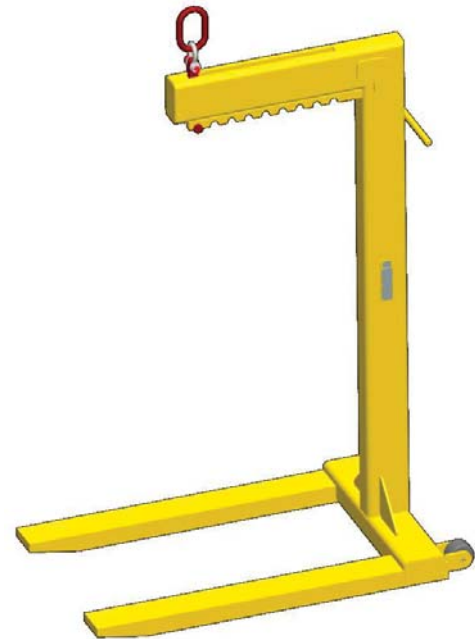

RFID TRACKING



CHIP EQUIPPED



- Converts crane or hoist into aerial forklift.
- Rear guide for operator safety.
- Fork Length : 36"
- Fork Spacing : 25"
- Dual Lift Bale adjustment.

Working Load Limit in Pounds*	Part Number	Weight in Pounds
2,000	14538	195
4,000	14537	345

* Call for specifications on larger sizes and capacities

MATERIAL HANDLING