

# NER Food Grade Electric Hoists

## Food grade hoist customized to fit your needs

Harrington's NER food grade electric hoists were carefully designed for food processing or food packaging applications. The hoists offer RoHS compliance, and its food grade lubricants comply with FDA standards, making them the perfect choice for any facility where incidental contact with product is a concern.

This three phase electric hoist includes all of the top quality features of our standard NER hoist and can be coupled with a push, geared or motorized trolley.

## Safe and Efficient

### Standard Food Grade Features

- 1/4–2 Ton capacities
- Food grade oil and grease
- Voltages 208-230/460-3-60
- White epoxy paint for hoists, trolleys, hooks and suspenders
- Nickel-plated load chain
- Canvas chain container
- Lubricants comply with FDA standards
- ASME H4 classification
- Stainless steel and nickel-plated components

### Available Options

- Stainless steel bottom hook
- Stainless steel trolley wheels
- Stainless steel side guide rollers
- Nickel-plated shaft and suspender
- Stainless steel or plastic chain container
- Nickel-diffused load chain
- NEMA 4 pendant
- Pendant cover
- Stainless steel chain spring and limiting plate
- Stainless steel cushion rubber
- Nickel-plated stopper

### Applications

- Food handling
- Food processing facilities
- Lift, support and discharge bulk materials
- A variety of processing industries

**Ask your local sales representative or call our Customer Service staff for friendly and expert advice on models and options.**



**MODEL: NERM020L-L-FG**  
*(Shown with optional stainless steel chain container and stainless steel bottom hook)*



NERM020L-L-FG with options

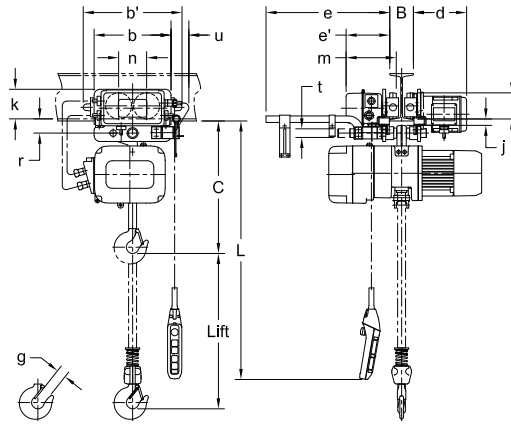

NERM020L-L-FG



NERP010LD-FG

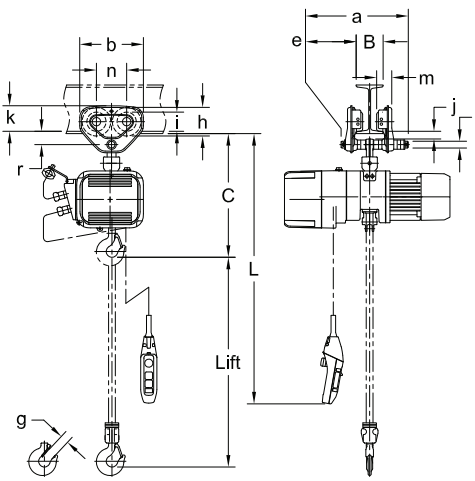

NERP010LD-FG

### Standard Product Features

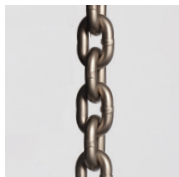

Nickel-Plated Load Chain



White Epoxy Paint



White Epoxy Bottom Hook



Stainless Steel Hook Latch



Canvas Chain Container

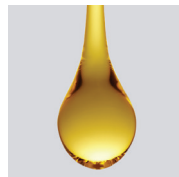

Food Grade Oil and Grease



Stainless Steel and Nickel-Plated Components

### Optional Product Features

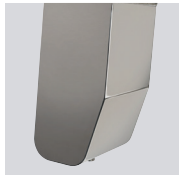

Stainless Steel Chain Container



Plastic Chain Container

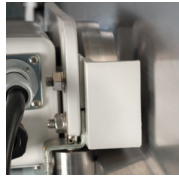

Stainless Steel Trolley Wheels (MR)



Stainless Steel Wheels (PT)



Stainless Steel Guide Roller

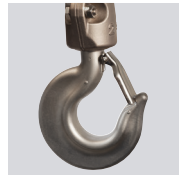

Stainless Steel Bottom Hook



Stainless Steel Cushion Rubber



Stainless Steel Chain Spring and Limiting Plate



Nickel-Plated Stopper



Nickel-Plated Suspension Shaft and Suspender



Nema 4 Pendant

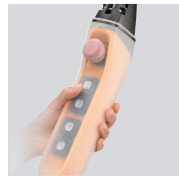

Pendant Cover

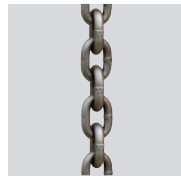

Nickel-Diffused Chain

### NERM FOOD GRADE SINGLE SPEED HOIST WITH SINGLE SPEED TROLLEY — SPECIFICATIONS

Cap. (Tons)	Product Code	Std. Lift (ft)	Push Button Cord L (ft)	Lifting Speed (ft/min)	Traversing Speed (ft/min)	Lifting Motor 3 Phase 60 Hz			Traversing Motor 3 Phase 60 Hz			Flange Width Adjustability B (in)		Minimum Allow. Radius for Curve (in)	Load Chain Diameter (mm) x Chain Fall Lines	Net Weight (lbs)	Weight for Additional One Foot of Lift (lbs)
						Output (Hp)	Rated Current (amps)		Output (Hp)	Rated Current (amps)		Standard	Optional				
							@208-230V	@460V		@208-230V	@460V						
1/4	NERM003L-L/S-FG	10	8.2	15	L = 40 S = 80	0.75	3.4	1.7	0.54	3.2	1.6	2.28 to 5.00	5.01 to 6.02 OR 6.03 to 12.00	31.5*	6.0 x 1	139	0.54
1/2	NERM005L-L/S-FG			14		1.2	4.8	2.5	0.54	3.2	1.6				7.7 x 1	170	0.89
1	NERM010L-L/S-FG			14		2.4	8.6	4.2	0.54	3.2	1.6	3.23 to 6.02	6.03 to 7.02 OR 7.03 to 12.00	31.5**	10.2 x 1	245	1.6
2	NERM020L-L/S-FG			14		2.4	8.6	4.2	0.54	3.2	1.6				10.2 x 1	245	1.6

\*Flange widths smaller than 4 inches will have a minimum radius of 137.8 inches.

\*\*Flange widths smaller than 5 inches will have a minimum radius of 39.4 inches.

### NERM FOOD GRADE SINGLE SPEED HOIST WITH SINGLE SPEED TROLLEY — DIMENSIONS

Cap. (Tons)	Product Code	Headroom C (in)	Headroom C w/Stainless Hook (in)	b (in)	b' (in)	d (in)	e (in)	e' (in)	g (in)	g w/Stainless Hook (in)	i (in)	j (in)	k (in)	m (in)	n (in)	r (in)	t (in)	u (in)
1/4	NERM003L-L/S-FG	15.6	18.7	12.4	15.6	8.7	20.3	7.1	1.1	1.2	3.74	0.9	5.1	8.1	4.3	2.0	1.22	3.3
1/2	NERM005L-L/S-FG																	
1	NERM010L-L/S-FG	17.1	21.5	12.4	15.6	8.7	20.3	7.1	1.2	1.5	3.74	0.9	5.1	8.1	4.3	2.0	1.22	3.3
2	NERM020L-L/S-FG	22.4	23.2	12.8	16.4	8.8	20.5	7.3	1.6	1.7	4.33	1.1	4.9	8.3	4.6	2.4	1.42	3.0

### NERM FOOD GRADE DUAL SPEED HOIST WITH DUAL SPEED TROLLEY — SPECIFICATIONS

Cap. (Tons)	Product Code	Std. Lift (ft)	Push Button Cord L (ft)	Lifting Speed (ft/min)	Traversing Speed (ft/min)	Lifting Motor*** 3 Phase 60 Hz			Traversing Motor*** 3 Phase 60 Hz			Flange Width Adjustability B (in)		Minimum Allow. Radius for Curve (in)	Load Chain Diameter (mm) x Chain Fall Lines	Net Weight (lbs)	Weight for Additional One Foot of Lift (lbs)
						Output (Hp)	Rated Current (amps)		Output (Hp)	Rated Current (amps)		Standard	Optional				
							@208-230V	@460V		@208-230V	@460V						
1/4	NERM003LD-SD-FG	10	8.2	15/2.5	80/13	0.75	3.6	1.8	0.54	3.4	1.7	2.28 to 5.00	5.01 to 6.02 OR 6.03 to 12.00	31.5*	6.0 x 1	141	0.54
1/2	NERM005LD-SD-FG					1.2	5.1	2.7	0.54	3.4	1.7				7.7 x 1	170	0.89
1	NERM010LD-SD-FG			14/2.5		2.4	9.1	4.5	0.54	3.4	1.7	3.23 to 6.02	6.03 to 7.02 OR 7.03 to 12.00	31.5**	10.2 x 1	247	1.6
2	NERM020LD-SD-FG			14/2.5		2.4	9.1	4.5	0.54	3.4	1.7				10.2 x 1	247	1.6

\*Flange widths smaller than 4 inches will have a minimum radius of 137.8 inches.

\*\*Flange widths smaller than 5 inches will have a minimum radius of 39.4 inches.

\*\*\*Although both 208/230 & 460 Volts are shown together, the motors are NOT reconnectable.

### NERM FOOD GRADE DUAL SPEED HOIST WITH DUAL SPEED TROLLEY — DIMENSIONS

Cap. (Tons)	Product Code	Headroom C (in)	Headroom C w/Stainless Hook (in)	b (in)	b' (in)	d (in)	e (in)	e' (in)	g (in)	g w/Stainless Hook (in)	i (in)	j (in)	k (in)	m (in)	n (in)	r (in)	t (in)	u (in)
1/4	NERM003LD-SD-FG	15.6	18.7	12.4	15.6	8.7	20.3	7.1	1.1	1.2	3.74	0.9	5.1	8.1	4.3	2.0	1.22	3.3
1/2	NERM005LD-SD-FG																	
1	NERM010LD-SD-FG	17.1	21.5	12.4	15.6	8.7	20.3	7.1	1.2	1.5	3.74	0.9	5.1	8.1	4.3	2.0	1.22	3.3
2	NERM020LD-SD-FG	22.4	23.2	12.8	16.4	8.8	20.5	7.3	1.6	1.7	4.33	1.1	4.9	8.3	4.6	2.4	1.42	3.0

## NERP FOOD GRADE SINGLE SPEED HOIST WITH PUSH TROLLEY — SPECIFICATIONS

Cap. (Tons)	Product Code	Std. Lift (ft)	Push Button Cord L (ft)	Lifting Speed (ft/min)	Lifting Motor 3 Phase 60 Hz			Flange Width Adjustability B (in)		Minimum Allow. Radius for Curve (in)	Load Chain Diameter (mm) x Chain Fall Lines	Net Weight (lbs)	Weight for Additional One Foot of Lift (lbs)
					Output (Hp)	Rated Current (amps)		Standard	Optional				
						@208-230V	@460V						
1/4	NERP003L-FG	10	8.2	15	0.75	3.4	1.7	2.28 to 4.00	4.01 to 8.00 OR 8.01 to 12.00	43.3	6.0 x 1	82	0.54
1/2	NERP005L-FG												
1	NERP010L-FG			14	1.2	4.8	2.5	2.28 to 5.00	5.01 to 8.00 OR 8.01 to 12.00	51.2	7.7 x 1	121	0.89
2	NERP020L-FG												

\*Minimum Flange Width for curved beam: 1 Ton Push = 2.87 in.

## NERP FOOD GRADE SINGLE SPEED HOIST WITH PUSH TROLLEY — DIMENSIONS

Cap. (Tons)	Product Code	Headroom C (in)	Headroom C w/Stainless Hook (in)	a (in)	b (in)	e (in)	g (in)	g w/Stainless Hook (in)	h (in)	i (in)	j (in)	k (in)	m (in)	n (in)	r (in)	t (in)
1/4	NERP003L-FG	16.3	19.5	8.0	7.2	1.8	1.1	1.2	3.2	2.36	0.8	3.0	1.9	3.3	1.5	0.87
1/2	NERP005L-FG															
1	NERP010L-FG	18.5	22.8	9.8	9.3	2.2	1.2	1.5	4.2	2.80	1.1	3.7	2.2	4.4	2.0	0.98
2	NERP020L-FG	25.0	25.8	11.8	11.0	2.7	1.6	1.7	5.0	3.35	1.4	4.4	2.8	5.2	2.4	1.26

## NERP FOOD GRADE DUAL SPEED HOIST WITH PUSH TROLLEY — SPECIFICATIONS

Cap. (Tons)	Product Code	Std. Lift (ft)	Push Button Cord L (ft)	Lifting Speed (ft/min)	Lifting Motor 3 Phase 60 Hz			Flange Width Adjustability B (in)		Minimum Allow. Radius for Curve (in)	Load Chain Diameter (mm) x Chain Fall Lines	Net Weight (lbs)	Weight for Additional One Foot of Lift (lbs)
					Output (Hp)	Rated Current (amps)		Standard	Optional				
						@208-230V	@460V						
1/4	NERP003LD-FG	10	8.2	15/2.5	0.75	3.6	1.8	2.28 to 4.00	4.01 to 8.00 OR 8.01 to 12.00	43.3	6.0 x 1	80	0.54
1/2	NERP005LD-FG												
1	NERP010LD-FG			14/2.5	1.2	5.1	2.7	2.28 to 5.00	5.01 to 8.00 OR 8.01 to 12.00	51.2	7.7 x 1	117	0.89
2	NERP020LD-FG												

\*Minimum Flange Width for curved beam: 1 Ton Push = 2.87 in.

\*\*Although both 208/230 & 460 Volts are shown together, the motors are NOT reconnectable.

## NERP FOOD GRADE DUAL SPEED HOIST WITH PUSH TROLLEY — DIMENSIONS

Cap. (Tons)	Product Code	Headroom C (in)	Headroom C w/Stainless Hook (in)	a (in)	b (in)	e (in)	g (in)	g w/Stainless Hook (in)	h (in)	i (in)	j (in)	k (in)	m (in)	n (in)	r (in)	t (in)
1/4	NERP003LD-FG	16.3	19.5	8.0	7.2	1.8	1.1	1.2	3.2	2.36	0.8	3.0	1.9	3.3	1.5	0.87
1/2	NERP005LD-FG															
1	NERP010LD-FG	18.5	22.8	9.8	9.3	2.2	1.2	1.5	4.2	2.80	1.1	3.7	2.2	4.4	2.0	0.98
2	NERP020LD-FG	25.0	25.8	11.8	11.0	2.7	1.6	1.7	5.0	3.35	1.4	4.4	2.8	5.2	2.4	1.26



**Harrington Hoists, Inc.**  
 401 West End Avenue, Manheim, PA 17545  
 717-665-2000 / 800-233-3010 / Fax: 717-665-2861  
 www.harringtonhoists.com

**Harrington Hoists, Inc.—Western Division**  
 2341 Pomona Road, No. 103  
 Corona, CA 92880-6973  
 951-279-7100 / 800-317-7111 / Fax: 951-279-7500

Specifications and dimensions are subject to change without notice.  
 Rev 0 Copyright ©2013 1-13  
 Item No. SS-NER-FG