



HARRINGTON
HOISTS AND CRANES

TCS Cheetah Air Powered Hoists



Model: TCS500P

High Speed Lifting Solution

Harrington's TCS Cheetah air powered hoist is available in 1/2 Ton capacity with either pendant or cord control. This hoist has extremely fast and uniquely adjustable lifting and lowering speeds. It's light weight, compact and has outstanding feathering ability making the TCS a perfect fit for fast-paced assembly line and workstation crane applications.

Superior performance and control

Ease of Use

- Unlimited duty cycle permits continuous operation
- Low noise levels add to operator comfort
- Low air consumption required for use
- Flexible pendant hose for better operator range of motion
- Lightweight, compact aluminum body offers excellent headroom

Maximum Control

- Vane motor design permits fine feathering control
- Extremely high lifting and lowering speeds
- Speeds are adjustable to fit every application
- Pilot pendant air maintains hoist performance when equipped with longer pendant lengths

Dependability

- Disc brake for reliable load support
- Supported by a full line of replacement parts
- Suitable for outdoor or extremely harsh environments
- 1/4 and 1 Ton models to be released soon

Ask your local sales representative or call our Customer Service staff for friendly and expert advice on models and options.

TCS PENDANT MODEL - SPECIFICATIONS

Cap. (Tons)	Product Code	Standard Lift (ft)	Push Button Hose L (ft)	Up/Down Speeds (ft/min @ 90 psi)		Up/Down Air Consumption Rates (cubic ft/min @ 90 psi)		Load Chain Diameter (mm) x Chain Fall Lines	Net Weight (lbs)	Weight for Additional One Foot of Lift (lbs)
				No Load	w/Full Load	No Load	w/Full Load			
1/2	TCS500P	10	8.1	108/62	60/109	74/64	60/71	6.3 x 1	42	0.6

TCS PENDANT MODEL - DIMENSIONS

Cap. (Tons)	Product Code	Headroom C (in)	a (in)	b (in)	d (in)	e (in)	g (in)	h (in)	i (in)	j (in)
1/2	TCS500P	16.3	14.4	8.7	6.3	7.6	1.0	5.3	3.3	1.0

TCS CORD MODEL - SPECIFICATIONS

Cap. (Tons)	Product Code	Standard Lift (ft)	Cord L (ft)	Up/Down Speeds (ft/min @ 90 psi)		Up/Down Air Consumption Rates (cubic ft/min @ 90 psi)		Load Chain Diameter (mm) x Chain Fall Lines	Net Weight (lbs)	Weight for Additional One Foot of Lift (lbs)
				No Load	w/Full Load	No Load	w/Full Load			
1/2	TCS500C	10	7.3	108/62	60/109	74/64	60/71	6.3 x 1	40	0.6

TCS CORD MODEL - DIMENSIONS

Cap. (Tons)	Product Code	Headroom C (in)	a (in)	b (in)	d (in)	e (in)	g (in)	h (in)	i (in)	j (in)
1/2	TCS500C	16.3	14.4	8.7	6.3	7.6	1.0	5.3	3.3	1.0

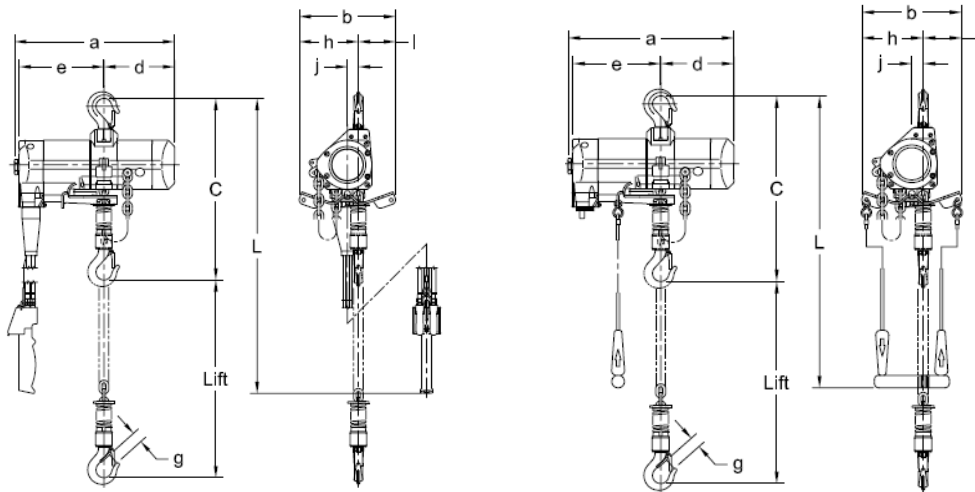

TCS500C



Harrington Hoists, Inc.
 401 West End Ave.
 Manheim, PA, 17545
 717-665-2000 / 800-233-3010
 Fax: 717-665-2861
 www.harringtonhoists.com

Harrington Hoists, Inc – Western Division
 2341 Pomona Rincon Road, No. 103
 Corona, CA 92880
 951-279-7100 / 800-317-7111
 Fax: 951-279-7500

Specifications and dimensions are subject to change without notice.
 Rev 0 Copyright © 2006 8-06
 Item No. SS-TCS